

SPECIAL ACCESS SERVICE

	Page	
I.	GENERAL	5
A.	Channel Types	5
B.	Service Description	8
C.	Service Configurations	9
D.	Alternate Use	13
E.	Special Facilities Routing	13
II.	RATE REGULATIONS	14
A.	Rate Categories	14
B.	Types of Rates and Charges	17
C.	Moves	21
D.	Minimum Periods	22
E.	Reserved for Future Use	23 (C)
F.	Facility Hubs	24
III.	VOICE GRADE SERVICE	27
A.	Basic Channel Description	27
B.	Optional Features and Functions	27
IV.	RESERVED FOR FUTURE USE	32 (C) (D)
V.	DIGITAL DATA SERVICE	33
A.	Basic Channel Description	33

By: Tariff Administrator
Title:
Issued:



Effective:

B.	Optional Features and Functions	33	
VI.	HIGH CAPACITY SERVICE	34	
A.	Basic Channel Description	34	
B.	Customer Options	34	
VII.	RATES AND CHARGES	38	
A.	Voice Grade Service	38	
B.	Reserved for Future Use	43	(C)
C.	Digital Data Service	44	
D.	High Capacity Service	47	
E.	Trouble Isolation Charge	51	

By: Tariff Administrator
Title:
Issued:



Effective:

SPECIAL ACCESS SERVICE

	Page
VIII. SIGNALING SYSTEM 7	52
A. Basic Channel Description	52
B. Rates and Charges	52
IX. SYNCHRONOUS OPTICAL CHANNEL SERVICE	53
A. General	53
B. Rates and Charges	57
X. RESERVED FOR FUTURE USE	59 (C)

(D)

(D)

By: Tariff Administrator
Title:
Issued:



Effective:

XI.	PUBLIC PACKET DATA	72
A.	General	72
B.	Service Description	72
C.	Ordering Options and Conditions	74
D.	Acceptance Testing	74
E.	Rate Regulations	74

By: Tariff Administrator
Title:
Issued:



SPECIAL ACCESS SERVICE

I. GENERAL

Special Access Service provides a transmission path to connect designated premises*, directly, through the GTA hub where bridging or multiplexing functions are performed, or to connect a customer designated premises. Special Access Service includes all digital exchange connections not utilizing GTA end office switching capability. (C)

A. Channel Types

There are four types of channels used to provide Special Access Services. Each type has its own characteristics. All are subdivided by one or more of the following: (C)

- Transmission specifications,
- Speed (i.e., bit rate),
- Bandwidth,
- Spectrum

Customers can order a basic channel and select from a list of those available transmission parameters and channel in interfaces that they desire in order to meet specific communications requirements.

* GTA Centrex CO and Co-like switches and packet switches included in Public Packet Switching Network (PPSN) Service is considered to be a customer-designated premises for purposes of this tariff.

By: Tariff Administrator
Title:
Issued:



Effective:

SPECIAL ACCESS SERVICE

I. GENERAL (cont'd)

A. Channel Types (cont'd)

For purposes of ordering channels, each has been identified as a type of Special Access Service. However, such identification is not intended to limit a customer's use of the channel nor to imply that the channel is limited to a particular use.

Following is a brief description of each type of channel:

Voice Grade - a channel for the transmission of analog signals within an approximate bandwidth of 300 to 3000 Hz.

(D)

(D)

Digital Data - a channel for the digital transmission of synchronous serial data at rates of 2.4, 4.8, 9.6, 19.2, 56, or 64 kbps.

High Capacity - a channel for the transmission of isochronous serial digital data at rates of 1.544, 3.152, 6.312, 44.736 or 274.176 Mbps.

Synchronous Optical – a high speed channel for the transmission of synchronous full duplex data over optical fiber at rates of 155.52 or 622.08 Mbps.

(N)

(N)

By: Tariff Administrator
Title:
Issued:



Effective:

SPECIAL ACCESS SERVICE

I. GENERAL (cont'd)

A. Channel Types (cont'd)

Detailed descriptions of each of the channel types are provided in III. through IV. following.

The customer also has the option of ordering High Capacity facilities (i.e., 1.544 Mbps, 3.152 Mbps, 6.312 Mbps, 44.736 Mbps and 274.176.Mbps) to GTA's hub for multiplexing to individual channels of a lower capacity or bandwidth. Descriptions of the types of multiplexing available at the hub, as well as the number of individual channels which may be derived from each type of facility are set forth below. Additionally, the customer may specify optional features for the individual channels derived from the facility to further tailor the channel to meet specific communications requirements. Descriptions of the optional features and functions available are set forth below. (C)

For example, a customer may order a 3.152 Mbps High Capacity channel from a customer designated premises to GTA's hub for multiplexing to two 1.544 Mbps channels. The 1.544 Mbps channels may be further multiplexed at the same or a different hub to lower capacity channels or may be extended to other customer designated premises. Optional features may be added to either the 1.544 Mbps or the lower capacity channels. (C)

By: Tariff Administrator
Title:
Issued:



Effective:

SPECIAL ACCESS SERVICE

I. GENERAL (cont'd)

B. Service Descriptions

For the purpose of ordering, there are four categories for Special Access Service.

These are:

Service Designator Codes

Voice Grade	VG	(D)
Digital Data	DA	
High Capacity	HC	
Synchronous Optical	OC	(N)

Each service consists of a basic channel to which a technical specifications package (customized or predefined), channel interface(s) and, when desired, optional features and functions are added to construct the service desired by the customer.

Customized technical specifications packages will be provided where technically feasible. If GTA determines that the requested parameter specifications are not compatible, the customer will be advised and given the opportunity to change the order.

When a customized channel is ordered the customer will be notified whether additional Engineering Charges apply. In such cases, the customer will be advised and given the opportunity to change the order.

By: Tariff Administrator
Title:
Issued:



Effective:

SPECIAL ACCESS SERVICE

I. GENERAL (cont'd)

B. Service Descriptions (cont'd)

The channel descriptions provided following, specify the characteristics of the basic channel and indicate whether the channel is provided between customer designated premises, between a customer designated premises and the GTA hub where bridging or multiplexing functions are performed, or between customer designated premises.

The optional features and functions available with each type of Special Access Service are described in this section. The optional features and functions information also indicates with which technical specifications packages they are available.

C. Service Configurations

There are two types of service configurations over which Special Access Services are provided: two-point service and multipoint service.

1. Two-Point Service

A two-point service connects two customer designated premises, either on a directly connected basis or through a hub where multiplexing functions are performed, or a customer designated premises.

Applicable rate elements are:

- Channel Terminations (one per customer designated premises)
- Local Network Interface Charges (one per customer designated premises)* (T)
- Optional Features and Functions
(when applicable)

* For Special Access circuits in service prior to the effective date of introduction of the Local Network Interface Charge for which there were no associated Channel Mileage facility or Channel mileage Termination Charges, the Local Network Interface Charge may not apply. See section II.A.3 for applicable regulation.

By: Tariff Administrator
Title:
Issued:



Effective:

(N)
|
(N)

SPECIAL ACCESS SERVICE

I. GENERAL (cont'd)

C. Service Configurations (cont'd)

1. Two-Point Service (cont'd)

The following diagram depicts a two-point Voice Grade service connecting two Customer Designated Premises (CDP).

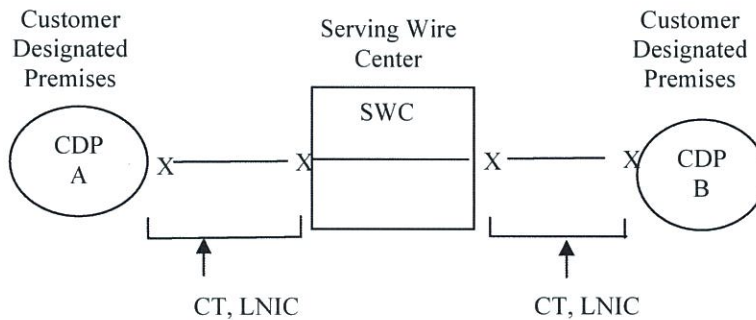

— CT, Channel Terminations (applicable one (1) per CDP)

— LNIC, Local Network Interface Charge (applicable one (1) per CDP)*

Applicable rate elements are:

— Channel Terminations (two (2) applicable)

— Local Network Interface Charges (two (2) applicable)

* For Special Access circuits in service prior to the effective date of introduction of the Local Network Interface Charge for which there were no associated Channel Mileage facility or Channel mileage Termination Charges, the Local Network Interface Charge may not apply. See section II.A.3 for applicable regulation.

By: Tariff Administrator
 Title:
 Issued:



Effective:

SPECIAL ACCESS SERVICE

I. GENERAL (cont'd)

C. Service Configurations (cont'd)

2. Multipoint Service

Multipoint service connects three or more customer designated premises through the GTA hub. Only certain types of Special Access Service are provided as multipoint service. These are so designated in the descriptions for the appropriate channel.

(C)

(D)

(D)

Multipoint service utilizing a customized technical specifications package will be provided when technically possible. If the GTA determines that the requested characteristics for a multipoint service are not compatible, the customer will be advised and given the opportunity to change the order.

(D)

Applicable Rate Elements are:

- Channel Terminations (one per customer designated premises)
- Local Network Interface Charges (one per customer designated premises)*
- Bridging
- Additional Optional Features and Functions (when applicable)

(C)

* For Special Access circuits in service prior to the effective date of introduction of the Local Network Interface Charge for which there were no associated Channel Mileage facility or Channel mileage Termination Charges, the Local Network Interface Charge may not apply. See section II.A.3 for applicable regulation.

(N)

(N)

By: Tariff Administrator
Title:
Issued:



Effective:

SPECIAL ACCESS SERVICE

I. GENERAL (cont'd)

C. Service Configurations (cont'd)

2. Multipoint Service (cont'd)

The following diagram depicts a Voice Grade multipoint service for connecting designated premises (CDP) via bridging at switched hub. (C)

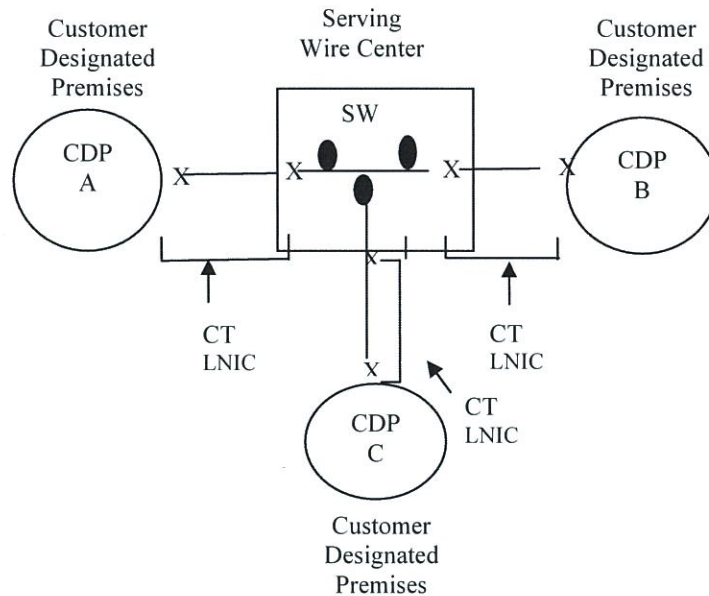

CT – Channel Termination (applicable one (1) per CDP)

LNIC – Local Network Interface Charge (applicable one (1) per CDP)* (C)
 •- Bridging Port

* For Special Access circuits in service prior to the effective date of introduction of the Local Network Interface Charge for which there were no associated Channel Mileage facility or Channel mileage Termination Charges, the Local Network Interface Charge may not apply. See section II.A.3 for applicable regulation. (N)

By: Tariff Administrator
 Title:
 Issued:



Effective:

SPECIAL ACCESS SERVICE

I. GENERAL (cont'd)

C. Service Configurations (cont'd)

2. Multipoint Service (cont'd)

Applicable rate elements are:

- Channel Terminations (3 applicable) (C)
- Local Network Interface Charge (3 applicable)* (D)
- (N)

D. Alternate Use

Alternate Use occurs when a service is arranged by GTA so that the customer can select different types of transmission at different times. A customer may use a service in any privately beneficial manner. However, where technical or engineering changes are required to effectuate an alternate use, GTA will make such special arrangements available on an individual case basis.

The arrangement required to transfer the service from one operation to the other (i.e., the transfer relay and control leads) will be rated and provided on an individual case basis. The customer will pay the slated tariff rates for the Access Service rate elements for the service ordered [i.e. Channel Terminations and Optional Feature and Functions (if any)]. (C)

E. Special Facilities Routing

A customer may request that the facilities used to provide Special Access Service be specially routed. The regulations, rates and charges for Special Facilities Routing are developed on an individual case basis.

* For Special Access circuits in service prior to the effective date of introduction of the Local Network Interface Charge for which there were no associated Channel Mileage facility or Channel mileage Termination Charges, the Local Network Interface Charge may not apply. See section II.A.3 for applicable regulation. (N)

By: Tariff Administrator
Title:
Issued:



Effective:

SPECIAL ACCESS SERVICE

II. RATE REGULATIONS

This section contains the specific regulations governing the rates and charges that apply for Special Access.

A. Rate Categories

There are two basic rate categories, which apply to Special Access Service: (C)

— Channel Terminations (D)

— Optional Features and Functions
— Local Network Interface Charge* (N)

1. Channel Termination

The Channel Termination rate category recovers the costs associated with the communications path between a customer designated premises and the serving wire center of that premises. Included as part of the Channel Termination is a standard channel interface arrangement which defines the technical characteristics associated with the type of facilities to which the access service is to be connected at the Point of Termination (POT) and the type of signaling capability, if any. The signaling capability is provided as an optional feature as set forth following. One Channel Termination charge applies per customer designated premises at which the channel is terminated. This charge will apply even if the customer designated premises and the serving wire center are collocated in a GTA building.

* For Special Access circuits in service prior to the effective date of introduction of the Local Network Interface Charge for which there were no associated Channel Mileage facility or Channel mileage Termination Charges, the Local Network Interface Charge may not apply. See section II.A.3 for applicable regulation.

(N)
|
(N)

By: Tariff Administrator
Title:
Issued:



Effective:

SPECIAL ACCESS SERVICE

(D)

(D)

By: Tariff Administrator
Title:
Issued:



Effective:

SPECIAL ACCESS SERVICE

II. RATE REGULATIONS ((cont'd)

A. Rate Categories (cont'd)

2. Optional Features and Functions (T)

The Optional Features and Functions rate category recovers the costs associated with optional features and functions, which may be added to a Special Access Service to improve its quality or utility to meet specific communications requirements. These are not necessarily identifiable with specific equipment, but rather represent the end result in terms of performance characteristics, which may be obtained. These characteristics may be obtained by using various combinations of equipment. Although the equipment necessary to perform a specified function may be installed at various locations along the path of the service, they will be charged for as a single rate element.

Examples of Optional Features and Functions that are available include, but are not limited to, the following:

- Signalling Capability
- Conditioning
- Hubbing Functions
- Transfer Arrangements

GTA has a single hub, comprising the serving wire center at which bridging or multiplexing functions are performed. The bridging functions performed are to connect three or more customer designated premises in a multipoint arrangement. The multiplexing functions are to channelize analog or digital facilities to individual services requiring a lower capacity or bandwidth. (C)

Descriptions for each of the available Optional Features and Functions are set forth following.

By: Tariff Administrator
Title:
Issued:

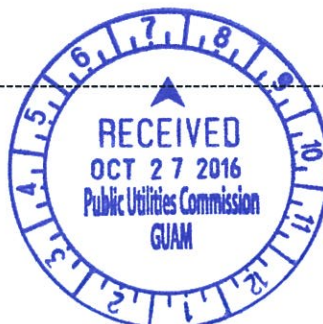

Effective:

SPECIAL ACCESS SERVICE

II. RATE REGULATIONS ((cont'd)

A. Rate Categories (cont'd)

3. Local Network Interface Charge

The Local Network Interface Charge (LNIC) rate category recovers, along with the Channel Termination (CT) charge, the costs associated with the communications path between a customer designated premises (CDP) and the Company's serving wire center (SWC). The LNIC is in addition to the CT charge. The LNIC charge will not apply if the CDP is local within the GTA SWC.

The LNIC, along with the CT charge, apply to each connection between the SWC and a CDP ordered on or after the effective date of the introduction of the LNIC in this tariff. Additionally, the LNIC replaces the Channel Mileage Facility (CMF) and Channel Mileage Termination (CMT), which charges applied to each connection between the SWC and CDP terminated by a CT or CTs.

Notwithstanding the above, in cases where no CMF or CMT charges applied to a connection between the SWC and a CDP in service prior to the effective date of introduction of the LNIC in this tariff, the LNIC will not apply for as long as the circuit is not terminated (CT charges will continue to apply). If such a circuit is terminated and customer later reactivates the circuit, the LNIC will apply.

B. Types of Rates and Charges

There are two types of rates and charges. These are monthly rates, and nonrecurring charges. The rates and charges are described as follows:

1 Monthly Rates

Monthly rates are recurring rates that apply each month or fraction thereof that a Special Access Service is provided. For billing purposes, each month is considered to have 30 days.

By: Tariff Administrator
Title:
Issued:



Effective:

(N)

(N)

(M)

(M)

SPECIAL ACCESS SERVICE

II. RATE REGULATIONS (cont'd)

B. Types of Rates and Charges (cont'd)

3. Nonrecurring Charges

Nonrecurring charges are one-time charges that apply for specific work activity (i.e., installation or change to an existing service). The types of nonrecurring charges that apply for Special Access Service are: installation of service, installation of optional features and functions, and service rearrangements.

a. Installation of Service

Nonrecurring charges apply to each service installed. The nonrecurring charges for the installation of service are set for each channel type as a nonrecurring charge for the Channel Termination.

b. Installation of Optional Features and Functions

When optional features and functions are installed coincident with the initial installation of service, no separate nonrecurring charge is applicable. When optional features and functions are installed or changed subsequent to the installation of service which requires additional engineering, the customer will incur a second installation charge.

c. Service Rearrangements

Service rearrangements are changes to existing (installed) services which may be administrative only in nature, as set forth following, or that involve actual physical change to the service.

By: Tariff Administrator
Title:
Issued:

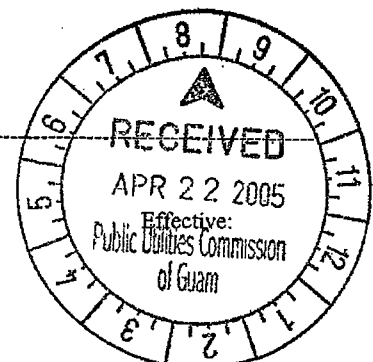

SPECIAL ACCESS SERVICE

II. RATE REGULATIONS (cont'd)

B. Types of Rates and Charges (cont'd)

3. Non-Recurring Charges (cont'd)

c. Service Rearrangements (cont'd)

Changes in the physical location of the point of termination or customer designated premises are moves as set forth following.

Changes in the type of Service or Channel Termination which result in a change of the minimum period requirement will be treated as a discontinuance of the service and an installation of a new service.

Changes in ownership or transfer of responsibility from one customer to another will be treated as a discontinuance of the service and an installation of a new service. In the event the change in ownership or transfer of responsibility is where there is no change in facilities or arrangements, the change will be treated as an administrative change.

By: Tariff Administrator
Title:
Issued:

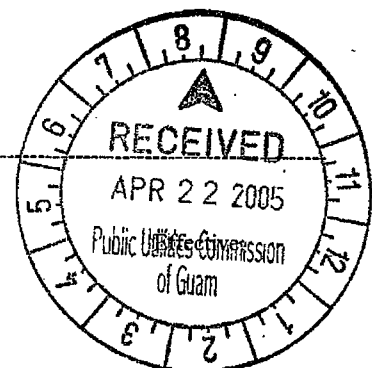

SPECIAL ACCESS SERVICE

II. RATE REGULATIONS (cont'd)

B. Types of Rates and Charges (cont'd)

3. Non-Recurring Charges (cont'd)

c. Service Rearrangements (cont'd)

Administrative changes will be made without charge(s) to the customer
Administrative changes are as follows:

-Change of customer name.

-Change of customer or customer's end user premises address
when the change of address is not a result of physical relocation
of equipment,

4. Service Rearrangements (cont'd)

— Change in billing data (name, address, or contact name or
telephone number)

— Change of agency authorization

— Change of customer circuit identification,

— Change of billing account number,

— Change of customer test line number.

— Change of customer or customer's end user contact name or
telephone number, and

— Change of jurisdiction.

By: Tariff Administrator
Title:
Issued:

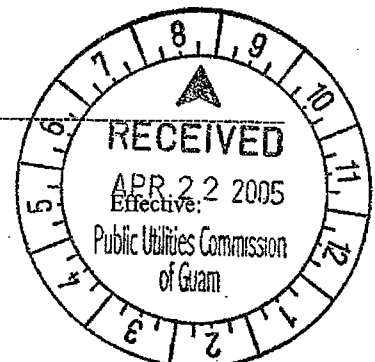

SPECIAL ACCESS SERVICE

II. RATE REGULATIONS (cont'd)

B. Types of Rates and Charges (cont'd)

3. Non-Recurring Charges (cont'd)

c. Service Rearrangements (cont'd)

All other service rearrangements will be charged as follows:

— If the change involves the addition of other customer designated premises to an existing service, the nonrecurring charge for the channel termination rate element will apply. The charge(s) will apply only for the location(s) that is being added.

— If the change involves the addition of an optional feature or function, or if the change involves changing the type of signaling on a Voice Grade service, and for all other changes, a service order charge will apply.

C. Moves

A move involves a change in the physical location of one of the following:

- The Point of Termination at the customer's premises;
- The customer's premises.

The charges for the move are dependent on whether the move is to a new location within the same building or to a different building.

By: Tariff Administrator
Title:
Issued:

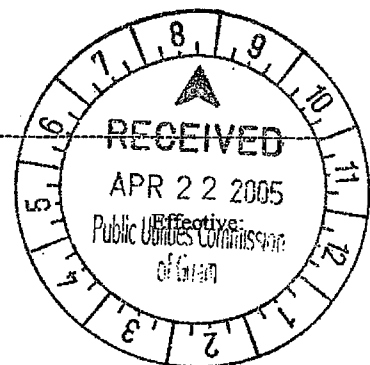

SPECIAL ACCESS SERVICE

II. RATE REGULATIONS (cont'd)

C. Moves (cont'd)

1. Moves Within the Same Building

When the move is to a new location within the same building, the charge for the move will be an amount equal to one half of the nonrecurring (i.e., installation) charge for the service termination affected. There will be no change in the minimum period requirements.

2. Moves to a Different Building

Moves to a different building will be treated as a discontinuance and start of service and all associated nonrecurring charges will apply. New minimum period requirements will be established for the new services. The customer will also remain responsible for satisfying all outstanding minimum period charges for the discontinued service.

3. Trunk Activation

Trunk Activation will be charge per 24 trunks activated or a fraction thereof, on a per order basis.

D. Minimum Periods

The minimum service period for all services is one month and the full monthly rate will apply to the first month.

By: Tariff Administrator
Title:
Issued:

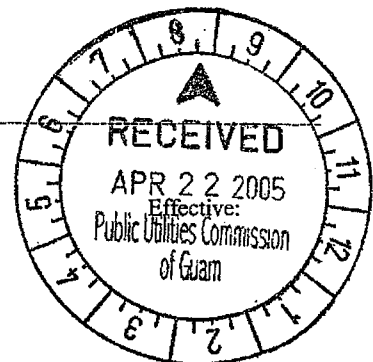

SPECIAL ACCESS SERVICE

II. RATE REGULATIONS (cont'd)

E. Mileage Measurement

The mileage used to determine the monthly rate for the Channel Mileage Facility is calculated on the airline distance between the locations involved, i.e.,

- the serving wire centers associated with two customer designated premises,;
- a serving wire center associated with a customer designated premises and an Authority's hub;
- two Authority's hubs.

The serving wire center associated with a customer designated premises is the serving wire center from which this customer designated premises would normally obtain dial lone.

Mileage charge are shown with each channel type. Mileage between GTA hubs is measured as follows:

<u>Route</u>	<u>Mile</u>
Agana - Dededo	6.15
Agana - Tumon	4.20
Tumon - Dededo	2.20

Mileage between the customer's serving wire center and GTA's hub is measured based on airline miles. When the calculation results in a fraction of a mile, always round up to the next whole mile before determining the mileage and applying the rates.

When hubs are involved, mileage is computed and rates applied separately for each section of the Channel Mileage, i.e.,

- customer designated premises serving wire center to hub, and/or
- hub to hub.

By: Tariff Administrator
Title:
Issued:

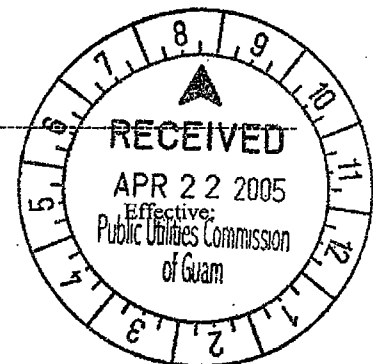

SPECIAL ACCESS SERVICE

II. RATE REGULATIONS (cont'd)

E. Mileage Measurement (cont'd)

However, when any service is routed through a hub for purposes other than customer specified bridging or multiplexing (e.g., GTA chooses to so route for test access purposes), rates will be applied only to the distance calculated between the serving wire centers associated with the customer designated premises.

F. Facility Hubs

A customer has the option of ordering High Capacity service (i.e., DS1, DS1C, DS2, DS3 or DS4) to a facility hub for channelizing to individual services requiring lower capacity facilities.

Different locations may be designated as hubs for different facility capacities, e.g., multiplexing from digital to digital may occur at one location while multiplexing from digital to analog may occur at a different location.

Some of the types of multiplexing available include the following:

- from higher to lower bit rate
- from higher to lower bandwidth
- from high capacity to voice frequency channels.

By: Tariff Administrator
Title:
Issued:

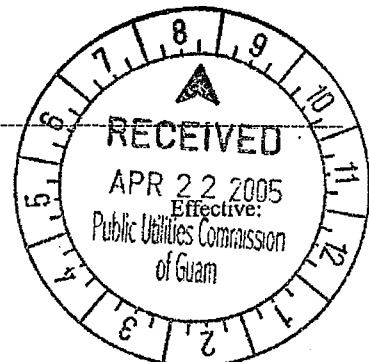

SPECIAL ACCESS SERVICE

II. RATE REGULATIONS (cont'd)

F. Facility Hubs

Point to point services may be provided on channels of these services to a hub. The transmission performance for the point to point service provided between customer designated premises will be that of the lower capacity or bit rate. For example, when a 1.544 Mbps channel is multiplexed to voice frequency channels, the transmission performance of the channelized services will be voice grade, not High Capacity.

GTA will commence billing the monthly rate for the service to the hub on the date specified by the customer on the Service Order. Individual channels utilizing these services may be installed coincident with the installation of the service to the hub or may be ordered and/or installed at a later date, at the option of the customer.

The customer will be billed for a High Capacity Channel Termination, Channel Mileage (when applicable), and the multiplexer at the time the service is installed. Individual service rates (by service type) will apply for a Channel Termination and additional Channel Mileage (as required) for each channelized service. These will be billed to the customer as each individual service is installed.

Cascading multiplexing occurs when a High Capacity service is de-multiplexed to provide channels with a lesser capacity and one of the lesser capacity channels is further de-multiplexed. For example, a 6.312 Mbps High Capacity service is de-multiplexed to four DS1 channels and then one of the DS1 channels is further demultiplexed to 24 individual voice grade Channels.

By: Tariff Administrator
Title:
Issued:

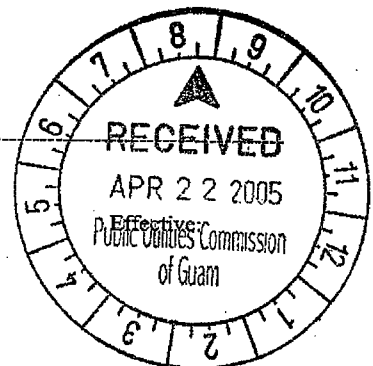

SPECIAL ACCESS SERVICE

II. RATE REGULATIONS (cont'd)

F. Facility Hubs (cont'd)

When cascading multiplexing is performed, whether in the same or a different hub, a charge for the additional multiplexing unit also applies. When cascading multiplexing is performed at different hubbing locations, Channel Mileage charges also apply between the hubs. GTA will designate hubs for Program Audio. Full-time or part-time service may be provided between Customer designated premises or between a Channel Termination. Channel Mileage and Optional Features and Functions, as applicable. When the service is ordered to a hub, the Customer may order a full-time or part-time Program Audio services as needed between the hub and additional Customer designated premises. The rate elements required to provide the part-time service (i.e., Channel Termination, Channel Mileage and Optional Features and Functions, as applicable) will be billed at daily rates for the duration of the service requested.

By: Tariff Administrator
Title:
Issued:

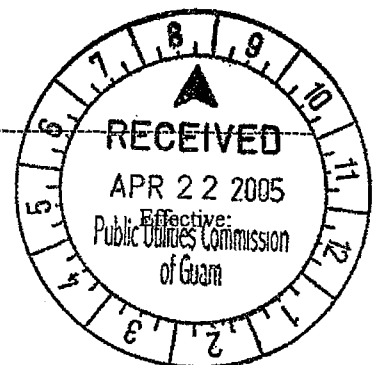

SPECIAL ACCESS SERVICE

III. VOICE GRADE SERVICE

A. Basic Channel Description

A Voice Grade channel is a channel, which provides voice frequency transmission capability in the nominal frequency range of 300 to 3000 Hz and may be terminated two-wire or four-wire. Voice Grade channels are provided between Customer designated premises, between a customer designated premises and a GTA hub or hubs.

Voice Grade Special Access Services are typically used for voice and voiceband data applications. Typical examples of voice grade circuits are Foreign Exchange lines (station end only), multipoint private line, voice trunk type, two-point voice grade data (one-way or simultaneous two-way), multipoint voice grade data, and voice grade telephoto or facsimile. These examples of applications are not intended to limit a customer's use of the channel nor to imply that the channel is limited to a particular use.

B. Optional Features and Functions

1. Central Office Bridging Capability
 - a. Voice Bridging (two-wire and four wire)
 - b. Data Bridging (two-wire and four wire)
 - c. Telephone Bridging (two-wire and four-wire)
 - d. DATAPHONE Select-A-Station Bridging with a sequential arrangement ports or addressable arrangement ports.
 - e. Telemetry and Alarm Bridging

Split Band, Active Bridging
Passive Bridging
Summation, Active Bridging

2. Central Office Multiplexing

Voice to Telegraph Grade. An arrangement that converts a Voice Grade channel to Telegraph Grade channel using frequency division multiplexing.

By: Tariff Administrator
Title:
Issued:



SPECIAL SERVICE ACCESS

III. VOICE GRADE SERVICE (cont'd)

B. Optional Features and Functions (Cont'd)

3. Conditioning (cont'd)

Conditioning provides more specific transmission characteristics for Voice Grade services.

For two -point services, the parameters apply to each service as measured end-to-end. For multipoint services, the parameters apply as measured on each mid-link or as measured on each end link. C-Type conditioning and Data Capability may be combined on the same service.

1. C-Type Conditioning

C-Type Conditioning is provided for the additional control of attenuation distortion and envelope delay distortion on data services.

2. Improved Attenuation Distortion

Improved Attenuation Distortion upgrades the frequency versus loss limits of the channel. This option is available only when ordered in combination with C-Type Conditioning.

3. Improved Envelope Delay Distortion

Improved Envelope Delay Distortion upgrades the frequency versus delay response limits of the channel. This option is available when ordered in combination with C-Type Conditioning.

4. Data Capability (D Conditioning)

Data Capability provides transmission characteristics suitable for data communication. Specifically Data Capability provides for the control of Signal to C-Notched Noise Ratio and intermodulation distortion. It is available for two point services or three-point multipoint services.

When a service equipped with data Capability is used for voice communications, the quality of the voice transmission may not be satisfactory.

By: Tariff Administrator
Title:
Issued:



SPECIAL ACCESS SERVICE

III. VOICE GRADE SERVICE (cont'd)

B. Optional Features and Functions (cont'd)

5. Signaling Capability

Signaling Capability provides for the ability to transmit signals from one Customer premises on the same service.

6. Selective Signaling Arrangements

An arrangement that permits code selective ringing for up to ten codes on a multipoint service.

7. Transfer Arrangements

An arrangement that affords the Customer an additional measure of flexibility in the use of an access channel(s). The arrangement can be utilized to transfer a leg of a Special Access Service to another channel that terminates in either the same or a different Customer premises. A key activated or dial-up control is required to operate the transfer arrangement. A spare channel, if required, is not included as part of the option.

8. Public Packet Switching Network (PPSN) Interface Arrangement

An arrangement that provides the interface requirements that permits a Voice Grade service to interface with a Public Packet Switching Network packet located in a GTA premises. The interface is compatible with X.25 and X.75 packet switching protocols as defined by the CCITT. This option is provided on an Individual Case Basis.

9. Four-Wire/Two-Wire Conversions

When a Customer requests that an effective four-wire channel be terminated with a two-wire channel interface at the Customer designated premises, a four-wire to two-wire conversion is required. The Customer will be charged the four-wire Channel Termination rate when an effective four-wire is specified in the order for service. The rate for the conversion is included as pan of the basic four-wire Channel Termination rate.

By: Tariff Administrator
Title:
Issued:



SPECIAL ACCESS SERVICE

III. VOICE GRADE SERVICE (cont'd)

B. Optional Features and Functions (cont'd)

10. Improved Two-Wire Voice Transmission

a. Loss Deviation

The maximum Loss Deviation of the 1004 Hz loss relative to the Expected Measured Loss (EML) is -4.0 dB to +4.0 dB.

b. Attenuation Distortion

The maximum Attenuation Deviation in the 404 to 280 Hz frequency band relative to loss at 1004 Hz is -2.0 dB to +6.0 dB.

c. C-Message

The maximum C-Message Noise for the transmission path at the route miles listed is less than:

<u>Route Miles</u>	<u>C-Message Noise</u>
Less than 50	35 dBrnc0
51 to 100	37 dBrnc0
101 to 200	40 dBrnc0
201 to 400	43 dBrnc0
401 to 1000	45 dBrnc0

By: Tariff Administrator
Title:
Issued:

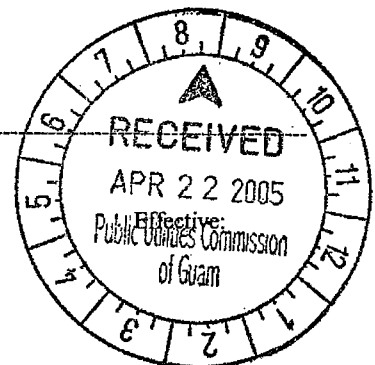

SPECIAL ACCESS SERVICE

III. VOICE GRADE SERVICE (cont'd)

B. Optional Features and Functions (cont'd)

11. Improved Two-Wire Voice Transmission (cont'd)

d. Return Loss

The Return Loss, expressed as Echo Return Loss (ERL) and Singing Return Loss (SRL), is equal to or greater than:

ERL	13.0 dB
SRL	6.0 dB

The rate for the provision of Improved Two-Wire Voice Transmission is included as part of the basic Channel Termination rate.

Ringdown Arrangements - An arrangement that affords the customer the ability to automatically transmit an audible ringing signal to the distant end of a private line voice grade channel when an off-hook condition exists at the other end of the circuit. Ringdown capability may be provided at multiple ends of a multi-point voice grade circuit or may be bi-directional. Each point of a multi-point circuit or each direction in a point-to-point circuit is considered an arrangement.

By: Tariff Administrator
Title:
Issued:

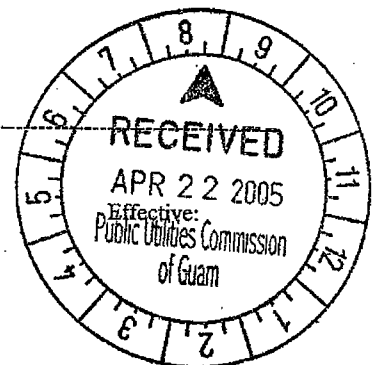

SPECIAL ACCESS SERVICE

IV. RESERVED FOR FUTURE USE

(C)

(D)

(D)

By: Tariff Administrator
Title:
Issued:



Effective:

SPECIAL ACCESS SERVICE

V. DIGITAL DATA SERVICE

A. Basic Channel Description

A Digital Data channel is a channel for duplex four-wire transmission of synchronous serial data at the rate of 2.4, 4.8, 9.6, 19.2, 56, or 64 Kbps. The actual bit rate is a function of the channel interface selected by the customer. The channel provides a synchronous service with timing provided by GTA through GTA facilities to the customer in the received bit stream. Digital Data channels are only available via GTA designated hubs and are provided between customer designated premises or between a customer designated premises and an GTA hub or hubs.

The customer may provide the Channel Service Unit-type equipment or other Network Channel Terminating Equipment associated with the Digital Data channel at the customer premises.

B. Optional Features and Functions

1. Central Office Bridging Capability
2. Transfer Arrangements

An arrangement that affords the customer an additional measure of protection and/or flexibility in the use of their access channel(s) on a IxN basis. The arrangement can be utilized to transfer a leg of a Special Access Service to either a spare or working channel that terminates in either the same or a different customer designated premises. A key activated or dial-up control service is required to operate the transfer arrangement. A spare channel, if required, is not included as a part of the option. (C)

3. Public Package Switching Network (PPSN) Interface Arrangement

An arrangement that provides the interface requirements that permit a Digital Data Service to interface with a Public Packet Switching Network packet switch located in an GTA premises. The interface is compatible with XI.25 and XI.75 packet switching protocols as defined by the CCITT. (C)

By: Tariff Administrator
Title:
Issued:



Effective:

SPECIAL ACCESS SERVICE

VI. HIGH CAPACITY SERVICE

A. Basic Channel Description

A High Capacity channel is a channel for the transmission of nominal 64.0 Kbps* or 1.544, 3.152, 6.132, 44.736, or 274.176 Mbps isochronous serial data. The actual bit rate is a function of the channel interface selected by the customer. High Capacity channels are provided between customer designated premises or between a customer designated premises and a GTA hub or hubs.

The customer may provide the Network Channel Terminating Equipment or the optical-to-electrical terminating equipment, on services provided over fiber cable, associated with the High Capacity channel at the customer's premises. On service arrangements where the customer provides the optical-to-electrical terminating equipment on both ends of a high capacity channel the customer must specify the bit rate capacity and GTA will limit the capacity of the channel to the bit rate specified by the customer.

B. Customer Options

1. Automatic Loop Transfer

The Automatic Loop Transfer provides protection on an IxN basis against failure of the facilities between a customer's designated premises and the wire center serving that premises. Protection is furnished through the use of a switching arrangement that automatically switches to a spare channel line when a working line fails. The spare channel is not included as a part of the option. This option requires compatible equipment at both the serving wire center and the customer-designated premises. The customer is responsible for providing the equipment at its designated premises.

* Available only as a channel of a 1.544 Mbps facility to a GTA Digital Data hub or as a cross connect of two 2.4, 4.8, 9.6, 19.2, 56.0 or 64.0 Kbps channels of two 1.544 Mbps facilities to a Digital Data hub(s). The customer must provide system and channel assignment data.

By: Tariff Administrator
Title:
Issued:

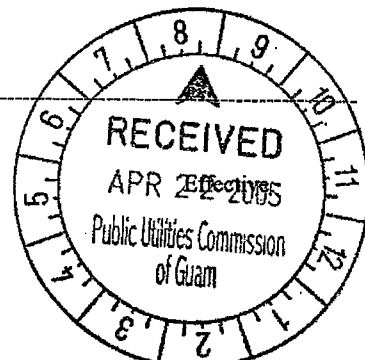

SPECIAL ACCESS SERVICE

VI. HIGH CAPACITY SERVICE (cont'd)

B. Customer Options (cont'd)

2. Customer Specified Bit Rate

The customer may specify other high capacity bit rates not specifically listed in paragraph A. of this section. If GTA can obtain optical-to-electrical terminating equipment that is compatible with its existing network facilities and equipment. Special construction charges as specified in Section 3 may apply to these arrangements for facilities or equipment that may not be used by GTA except for this one customer.

3. Transfer Arrangement

An arrangement that affords the customer an additional measure of flexibility in the use of their access channel(s). The arrangement can be utilized to transfer a leg of a Special Access Service to either a spare or working channel that terminates in either the same or a different customer designated premises. A key activated or dial-up control service is required to operate the transfer arrangement. A spare channel, if required, is not included as part of the option.

4. Central Office Multiplexing

a. DS4 to DSI

An arrangement that converts a 274.176 Mbps channel to 168 DSI channels using digital time division multiplexing.

b. DS3 to DSI

An arrangement that converts a 44.736 Mbps channel to 28 DSI channels using digital time division multiplexing.

c. DS2 to DSI

An arrangement that converts a 6.312 Mbps channel to four DSI channels using digital time division multiplexing.

d. DS1C to DSI

An arrangement that converts a 3.152 Mbps channel to two DSI channels using digital time division multiplexing.

By: Tariff Administrator
Title:
Issued:

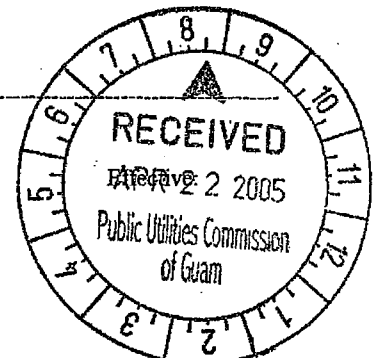

SPECIAL ACCESS SERVICE

VI. HIGH CAPACITY SERVICE (cont'd)

B. Customer Options (cont'd)

4. Central Office Multiplexing (cont'd)

5. DSI to Voice

An arrangement that converts a 1.544 Mbps channel to 24 channels for use with voice grade services. A channel(s) of this DSI to the Hub can also be used for a Digital Data Service.

6. DSI to DSO

An arrangement that converts a 1.544 Mbps channel to 23 64.0 Kbps channels utilizing digital time division multiplexing.

7. DSO to Subrate

An arrangement that converts a 64.0 Kbps channel to subspeeds of up to twenty 2.4 Kbps, Ten 4.8 Kbps, or five 9.6 Kbps channels using digital time division multiplexing.

By: Tariff Administrator
Title:
Issued:



Page 37 deleted

Tariff Transmittal # _____ Date _____

SPECIAL ACCESS SERVICE

VII. RATES AND CHARGES

A. Voice Grade

	<u>Monthly Rate</u>	<u>Nonrecurring Charge</u>	
1. Channel Termination Per Termination			
-- Two-wire	\$37.83	\$161.00	
-- Four-wire	\$60.53	\$161.00	
2. Reserved for Future Use			(C)
			(D)
			(D)
3. Optional Features and Functions			
a. Bridging			
i. Voice Bridging, Per Port			
-- Two-wire	\$6.50		
-- Four-wire	\$6.50		

By: Tariff Administrator
 Title:
 Issued:



Effective:

SPECIAL ACCESS SERVICE

VII. RATES AND CHARGES (cont'd)

A. Voice Grace Service (cont'd)

3. Optional Features and Functions (cont'd)

a. Bridging (cont'd)

	Monthly Rate	Nonrecurring Rate
i. Data Bridging per Port		
-- Two-Wire	\$6.50	
-- Four-Wire	\$6.50	
ii. Telephoto Bridging per Port		
-- Two-Wire	\$6.50	
-- Four-Wire	\$6.50	
iv. DATAPHONE Select-A-Station Bridging		
Sequential Arrange Ports per channel connected		
-- Two-Wire	\$22.19	
-- Four-Wire	\$117.70	
Addressable Arrangement, Ports Per Channel connected		
-- Two-Wire	\$23.75	
-- Four-Wire	\$102.80	

By: Tariff Administrator
Title:
Issued:

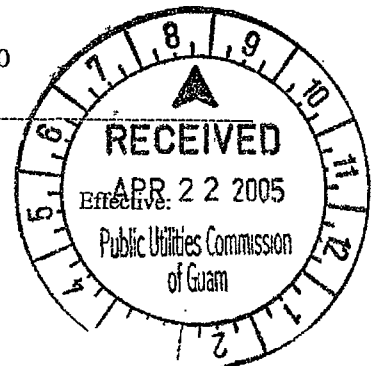

SPECIAL ACCESS SERVICE

VII. RATES AND CHARGES (cont'd)

A. Voice Grade (cont'd)

3. Optional Features and Functions (cont'd)

	<u>Monthly Rate</u>
a. Bridging	
Telemetry and Alarm Bridging	
Active Bridging Channel Channel per Channel Connected	
-- Split Band	\$ 8.89
-- Summation	\$ 3.47
Passive Bridging Channel Connections per Channel Connected	0.24
b. Conditioning per Termination	
C-Type	\$ 7.20

By: Tariff Administrator
Title:
Issued:

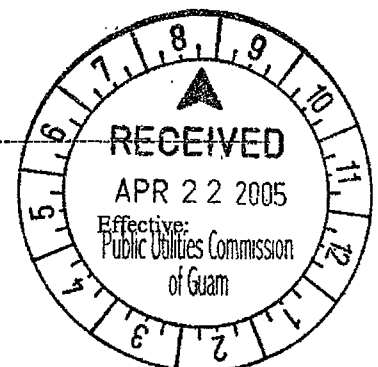

SPECIAL SERVICE ACCESS

VII. RATES AND CHARGES (cont'd)

A. Voice Grade (cont'd)

3. Optional Features and Functions (cont'd)

	<u>Monthly Rate</u>
Improved Attenuation	
Distortion	None
Improved Enveloped Delay Distortion	None
Data Capability	\$ 4.95
Telephone Capability	\$ 9.02
Sealing Current	None
c. Improved Return Loss for Effective Two-wire or Four-Wire Transmission Per Termination	
-- Two-Wire	\$12.80
-- Four-Wire	\$12.80
d. Cellular Carrier Specified Receive Level per two-wire termination	\$ 8.80

(D)
(D)

By: Tariff Administrator
Title:
Issued:



Effective:

SPECIAL SERVICE ACCESS

VII. RATES AND CHARGES (cont'd)

A. Voice Grade Service (cont'd)

3. Optional Features and Functions (cont'd)

	<u>Monthly Rate</u>	
e. Signaling Capability Per Termination	\$12.95	(T)
f. Selective Signaling Arrangement Per Arrangement	\$ 6.50	(T)
g. Transfer Arrangement (key activated or dial-up *)		(T) (C)
-- Per four port arrangement including control channel termination **	\$ 3.13	(C)
-- Per five port arrangement including control channel termination	\$ 7.14	

4. Local Network Interface Charge Per Termination	<u>Monthly Rate</u>	<u>Nonrecurring Rate</u>	(N)
--Two-wire	\$73.09	\$0.00	
--Four-wire	\$73.09	\$0.00	(N)

* The Dial-up option requires the Customer to purchase a Controller Arrangement. (D)
 (T)

** An additional Channel Termination charge will apply whenever a spare channel is configured as a leg to the Customer designated premises. (C)

By: Tariff Administrator
 Title:
 Issued:



Effective:

SPECIAL SERVICE ACCESS

VII. RATES AND CHARGES (cont'd)

B. Reserved for Future Use

(C)

(D)

(D)

By: Tariff Administrator
Title:
Issued:



Effective:

SPECIAL SERVICE ACCESS

VII. RATES AND CHARGES (cont'd)

(D)

(D)

C. Digital Data Service

1. Channel Termination
Per Termination

	<u>Recurring Charge</u>	<u>Nonrecurring Charge</u>	(N)
-- 2.4 kbps	\$69.82	\$177.00	
-- 4.8 kbps	\$69.82	\$177.00	
-- 9.6 kbps	\$69.82	\$177.00	
-- 19.2 kbps	\$69.82	\$177.00	
-- 56.0 kbps	\$69.82	\$177.00	
-- 64.0 kbps	\$69.82	\$177.00	

(N)

(D)

(D)

By: Tariff Administrator
Title:
Issued:



Effective:

SPECIAL SERVICE ACCESS

VII. RATES AND CHARGES (cont'd)

C. Digital Data Service (cont'd)

(D)

(D)

2. Optional Features and Functions

(T)

- | | | |
|----|---|--------|
| a. | Bridging, per port | \$7.85 |
| b. | Loop Transfer Arrangement
Per four port arrangement*
Key activated or Dial-Up** | \$6.21 |

* An additional Channel Termination charge will apply whenever a spare channel is configured as a leg to the customer designated premises.

(C)

** The Dial-up option requires the customer to purchase a Controller Arrangement.

By: Tariff Administrator
Title:
Issued:



Effective:

SPECIAL SERVICE ACCESS

VII. RATES AND CHARGES (cont'd)

C. Digital Data Service (cont'd)

2. Optional Features and Functions (cont'd) (T)

	<u>Monthly Rate</u>	<u>Nonrecurring Rate</u>
c. Public Packet Switching Network Interface Arrangement		
-- Per 9.6 kbps arrange- ment	ICB	
-- Per 19.2 kbps arrange- ment	ICB	
-- Per 56.0 kbps arrange- ment	ICB	
-- Per 64.0 kbps arrange- ment	ICB	

3. Local Network Interface Charge
Per Termination

	<u>Monthly Rate</u>	<u>Nonrecurring Rate</u>
--2.4 kbps	\$96.99	\$0.00
--4.8 kbps	\$96.99	\$0.00
--9.6 kbps	\$96.99	\$0.00
--19.2 kbps	\$96.99	\$0.00
--56.0 kbps	\$96.99	\$0.00
--64.0 kbps	\$96.99	\$0.00

(N)

(N)

(M)

(M)

By: Tariff Administrator
 Title:
 Issued:



Effective:

SPECIAL SERVICE ACCESS

VII. RATES AND CHARGES (cont'd)

D. High Capacity Service

	<u>Monthly Rate</u>	<u>Nonrecurring Charge</u>
1. Channel Termination Per Termination (1) (2)		
-- 1.544 Mbps	\$176.25	\$181.00
-- 3.153 Mbps	ICB	ICB
-- 6.312 Mbps	ICB	ICB
-- 6.312 Mbps/Customer Provided Optical-to-Electrical Terminating Equipment	ICB	ICB
-- 44.736 Mbps	\$2,051.19	\$499.00
-- 44.736 Mbps/Customer Provided Optical-to-Electrical Terminating Equipment	ICB	Per Channel ICB
-- 274.176 Mbps	ICB	ICB
-- 274.176 Mbps/Customer Provided Optical-to-Electrical Terminating Equipment	ICB	ICB
Trunk Activation Charge Per Activation		\$249.00

- (1) GTA will provide any of the ICB high capacity arrangements on a month by month basis or will offer on a fixed rate contract for up to 60 months. Fixed rate contracts are subject to termination liability charges if the customer disconnects the service before the term of the contract expires.
- (2) Since these high capacity services include specialized facilities and equipment GTA may require the customer to pay one-time special construction charges or require the customer to sign a termination liability contract for a period not to exceed 60 months.

By: Tariff Administrator
 Title:
 Issued:

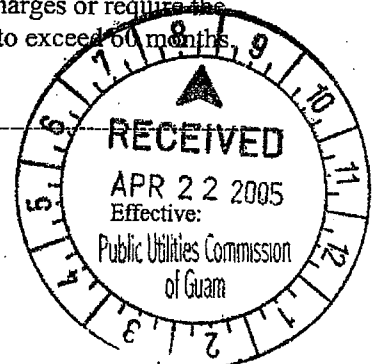

SPECIAL ACCESS SERVICE

VII. RATES AND CHARGES (cont'd)

D. High Capacity Service (cont'd)

(D)

(D)

By: Tariff Administrator
Title:
Issued:



Effective:

SPECIAL ACCESS SERVICE

VII. RATES AND CHARGES (cont'd)

D. High Capacity Service (cont'd)

	<u>Monthly Rate</u>	<u>Nonrecurring Rate</u>	
2. Optional Features and Functions			(T)
(1) (2)			
DS4 to DS1	ICB	ICB	
DS3 to DS1	\$474.31	\$474.31	
DS2 to DS1	ICB	ICB	
DS1C to DS1	ICB	ICB	
DS1 to Voice*	\$183.12		
DS1 to DS0	\$183.12		
DSO to Subrates			
-Up to 202.4 kbps services	\$390.00		
-Up to 104.8 kbps services	\$265.00		
-Up to 59.6 kbps services	\$235.00		

* A channel of this DS1 to the Hub can be used for Digital Data Services.

- (1) GTA will provide any of the ICB high capacity arrangements on a month to month basis or will offer on a fixed rate for up to 60 months. Fixed rate contracts are subject to termination liability chares if the customer disconnects the service before the term of the contract expires.
- (2) Since these high capacity services include specialized facilities and equipment GTA may also require the customer to pay one-time special construction charges or require the customer to sign a termination liability contract for a period not to exceed 60 months.

By: Tariff Administrator
 Title:
 Issued:



Effective:

SPECIAL ACCESS SERVICE

VII. RATES AND CHARGES (cont'd)

D. High Capacity Service (cont'd)

2. Optional Features and Functions (cont'd) (T)

	<u>Monthly Rate</u>	<u>Nonrecurring Rate</u>
a. Automatic Loop Transfer Per Arrangement*	\$158.00	
b. Transfer Arrangement (Key activated or dial up**) Per four port arrange- ment including control channel termination***	\$172.20	

	<u>Monthly Rate</u>	<u>Nonrecurring Rate</u>	(N)
3. Local Network Interface Charge			
--1.544 Mbps	\$155.44	\$0.00	
--3.153 Mbps	\$155.44	\$0.00	
--6.312 Mbps	\$155.44	\$0.00	
--44.736 Mbps	\$155.44	\$0.00	
--274.176 Mbps	\$155.44	\$0.00	
			(N)

* An additional Channel Termination charge will apply whenever the spare line is provided as a leg to the customer designated premises.

** The Dial-up option requires the customer to purchase the Controller Arrangement.

*** An additional Channel Termination charge will apply whenever a spare channel is configured] as a leg to the customer designated premises. (C)

By: Tariff Administrator
 Title:
 Issued:



Effective:

SPECIAL ACCESS SERVICE

VII. RATES AND CHARGES (cont'd)

E. Trouble Isolation Charge

1. General

In those instances where service difficulty or trouble identification by GTA results from customer-owned or maintained inside wire, and/or equipment, the customer is responsible for the payment of a Trouble Isolation Charge. This charge does not include time or materials to repair the customer owned or maintained inside wire, and/or equipment. This charge applies only to special access services. Upon request, GTA will make repairs at an additional charge.

2. Rates and Charges (1)

a. Business Maintenance of Service Charges

\$75.00 per trouble

(1) GTA offers to perform repair and maintenance work only during normal working hours from 8:00 a.m. to 5:00 p.m., Monday through Friday, except holidays. All repair and maintenance work performed at other than during normal hours at the customer's request shall be provided at premium rates.

By: Tariff Administrator
Title:
Issued:

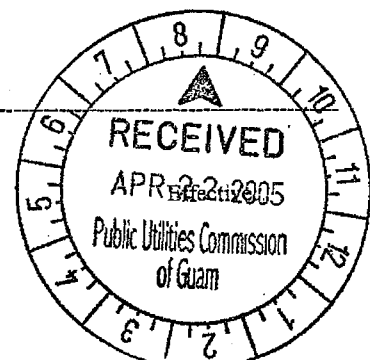

SPECIAL ACCESS SERVICE

VIII. SIGNALING SYSTEM 7 (SS7)

A. BASIC CHANNEL DESCRIPTION

1. Common Channel Signaling /Signaling System 7 (CCS/SS7) Network Connection Service (CCSNC) provides a signaling path between a customers designated Signaling Point of Interface (SPOI) and a Signaling Service Point (SSP) of GTA. This service provides customers with the use of a path for accessing information necessary for the completion of their end users calls.

CCS/SS7 Network Connection Service is comprised of: a Signaling Network Access Link (SNAL, consisting of Signaling Mileage Facility, Signaling Mileage Termination and Signaling Entrance Facility) and a Signaling Service Point. The SNAL is provided as digital transmission at a speed of 56 Kbps.

B. RATES AND CHARGES

	<u>Monthly Rate</u>	<u>Nonrecurring Rate</u>
(1) Signaling Mileage Facility, Per facility, per mile	\$3.96	
(2) Signaling Mileage Termination, Per Termination	\$39.79	
(3) Signaling Entrance Facility, Per Facility	\$69.82	
(4) STP Port, Per Port	\$455.00	
(5) Signaling Entrance Facility Installation		\$177.00
(6) SS7/MF Conversaion per 24 Trunks converted		\$260.00

By: Tariff Administrator
Title:
Issued:

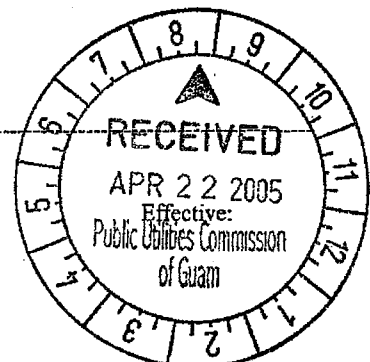

SPECIAL ACCESS SERVICE

IX. SYNCHRONOUS OPTICAL CHANNEL SERVICE

A. General

A Synchronous Optical Channel Service channel provides dedicated transport utilizing Synchronous Optical Network (SONET) transmission standards. Synchronous Optical Channel Service provides optical network capability to customers requiring connections at transmission rates of 155.52 Mbps (OC3) and 622.08 Mbps (OC12). Synchronous Optical Channel Service is provided between two customer designated premises centers or between a CDP and the serving wire center. In addition, customers may add or drop bandwidth capacity from the synchronous optical channel for delivery to a customer designated premises or Public Packet Data Network Service.

(C)
|
(C)

OC3/OC3c Synchronous Optical Channel Service may also be provided between a customer designated premises and GTA's designated DSL Access Service Connection Point.

Each channel will be configured with one working and one protect fiber pair within the same sheath between the CDP and the serving wire center of at the CDP which provides redundancy to protect the customer's service. Should a failure occur, the SONET technology will automatically switch the customer's transmission to the dedicated protect fiber pair.

The customer may provide node and port equipment at the CDP which allows the high speed optical carrier to be converted to an electrical signal at a lower speed. The provision of such equipment by the customer is subject to compatibility with GTA's equipment in the serving wire center and must comply with the standards specified in GR-253-CORE.

The OC3 channel is available in a non-concatenated format (OC3) which provides three individual signals. The OC3 channel is also available in a concatenated format (OC3c) which provides a single signal appropriate for data transmission.

By: Tariff Administrator
Title:
Issued:



Effective:

SPECIAL SERVICE ACCESS

IX. SYNCHRONOUS OPTICAL CHANNEL SERVICE (cont'd)

A. General (cont'd)

1. Network Channel Interfaces

Compatibles Network Channel Interfaces (NCI's) for Synchronous Optical Channel Service define the bit rates that are available for a synchronous optical channel:

<u>NCI</u>	<u>Bit Rate</u>
FCF-B	155.52 Mbps (OC3, OC3c)
FCF-D	622.08 Mbps (OC12)

2. Optical Features and Functions

a. Customer Node

A Customer Node charge applies when GTA provides terminal equipment at the customer designated premises for termination of a Synchronous Optical Channel Service Termination. Such equipment may be used to convert the signal from an optical to electrical format. The Customer Node Charge is determined by the level of optical service (i.e., OC3, OC3c or OC12) delivered to the premises. Each Customer Node Must be configured with one or more Customer Premises Ports.

b. Customer Premises Port

Customer Premises Port charges apply in conjunction with the Customer Charge. Each Customer Premises Port provides the interface to derive a lower capacity service at the customer premises. The type and quantity of ports is determined by the Customer Node selected and the number of DS1, DS3, and/or OC3, OC3c channels ordered. Customer Premises Ports are available at the following speeds:

By: Tariff Administrator
Title:
Issued:

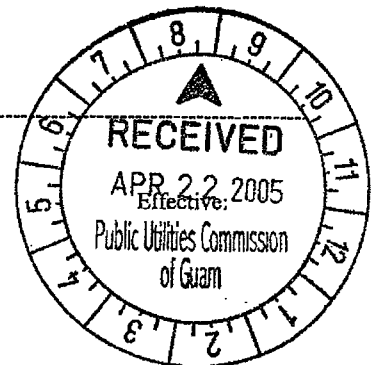

SPECIAL ACCESS SERVICE

IX. SYNCHRONOUS OPTICAL CHANNEL SERVICE (cont'd)

A. General (cont'd)

2. Optical Features and Functions (cont'd)

b. Customer Premises Port (cont'd)

<u>Customer Premises Port</u>	<u>Speed</u>
OC3, OC3c	155.52 Mbps
DS3	44.736 Mbps
DS1	1.544 Mbps

c. Add/Drop Multiplexing

An Add/Drop Multiplexing Central Office Port charge applies to the interface provided at a GTA's wire center for the purpose of adding or dropping lower capacity services from Synchronous Optical Channel Service Channel Termination. Central Office Ports are available at the following speeds:

(C)

<u>Customer Premises Port</u>	<u>Speed</u>
OC3, OC3c	155.52 Mbps
DS3	44.736 Mbps
DS1	1.544 Mbps

OC12 service may only be multiplexed to OC3/OC3c channels.

By: Tariff Administrator
Title:
Issued:



Effective:

SPECIAL ACCESS SERVICE

IX. SYNCHRONOUS OPTICAL CHANNEL SERVICE (cont'd)

A. General (cont'd)

2. Optical Features and Functions (cont'd)

c. Add/Drop Multiplexing (cont'd)

When an OC3 channel is derived from an OC12 service and is further multiplexed to obtain DS3 service, a DS3 port charge will apply in addition to the OC3 port charge.

When a DS3 channel is derived from an OC3 service and is further multiplexed to obtain DS1 service, a DS3 to DS1 Multiplexing charge as set forth in Section VII D.2, preceding, will apply in addition to the DS3 port charge. (C)

When a DS1 channel is directly derived from an OC3 service. A DS1 port charge will apply. (C)

When a DS1 channel is further multiplexed to a lower level signal, a DS1 to Voice Grade Multiplexing charge as set forth in Section VII D.2, preceding, will also apply. (C)

By: Tariff Administrator
Title:
Issued:



Effective:

SPECIAL ACCESS SERVICE

IX. SYNCHRONOUS OPTICAL CHANNEL SERVICE (cont'd)

B. RATES AND CHARGES

	<u>Monthly Rate</u>	<u>Non Recurring Charge</u>
Channel Termination, per Termination		
155.52 Mbps	\$1,361.19	\$786.00
622.08 Mbps	\$2,656.80	\$786.00

(D)

(D)

By: Tariff Administrator
Title:
Issued:



Effective:

SPECIAL ACCESS SERVICE

SECTION 9 SYNCHRONOUS OPTICAL CHANNEL SERVICE (cont'd)

II. Rates and Charges (cont'd)

B. Optional Features and Functions (cont'd)

	<u>Monthly Rate</u>	<u>Nonrecurring Rate</u>
Optional Features and Functions		
Customer Node, per Node		
155.52 Mbps	\$495.00	\$197.00
622.08 Mbps	\$1,430.00	\$197.00

Customer Premises Port, per Port

-- 1.544 Mbps	\$50.00	\$54.00
-- 44.736 Mbps	\$195.00	\$213.00
-- 155.52 Mbps	\$150.00	NONE

Add/Drop Multiplexing

-- OC3 Per Port	\$150.22
-- DS3 Per Port	\$100.15
-- DS1 Per Port	\$40.06

(D)

 (D)

By: Tariff Administrator
 Title:
 Issued:



Effective:

Pages 59-71deleted

Tariff Transmittal # _____ Date _____

SPECIAL ACCESS SERVICE

XI. PUBLIC PACKET DATA NETWORK

Public Packet Data Networks utilize separate data networks, comprised of switching and transmission facilities. The networks provide for the transfer of data provided by a customer in a frame format. The data is separated into discrete segments for transmission through the public packet data network.

FRAME RELAY ACCESS SERVICE

A. GENERAL

Frame Relay Access Service (FRAS) is a medium-speed, connection-oriented packet-switched data service that allows for the interconnection of Local Area Networks (LANs) or other compatible customer premises equipment for the purpose of connecting to an intrastate frame relay network. The terminal equipment accumulates the customer data and puts it into a frame relay format suitable for transmission over the FRAS network. This terminal equipment must conform to American National Standards Institute and Telecommunication Standardization Bureau of the International Telecommunication Union (ITU), formerly Committee Consultant de International Telegraphique et Telephonique (CCITT), standards.

FRAS permits customers to share network bandwidth for data transmissions.

Customers must certify that interstate usage of FRAS is less than 10% of total usage. If greater than 10% interstate usage is expected, FRAS service may be ordered through the NATIONAL EXCHANGE CARRIER ASSOCIATION (NECA) TARIFF F.C.C. No 5.

Rates and charges for FRAS are set forth in Section 9 following. The application of rates for FRAS is described in Original Page 71 following.

In addition to the regulations and charges specified in this section, the general regulations and charges specified in other sections of this tariff apply as appropriate.

B. SERVICE DESCRIPTION

FRAS is a transport service that facilitates the exchange of variable length information units (frames) between customer connections. Frames travel a fixed path through the network with an address that specifies the permanent virtual connection. Addresses are read by the network processor and the frames are relayed to the preassigned destination.

By: Tariff Administrator
Title:
Issued:



SPECIAL SERVICE ACCESS

XI. PUBLIC PACKET DATA NETWORK (cont'd)

B. Service Description (cont'd)

FRAS service includes: the Frame Relay Access Connection, the Frame Relay Inter-network Connection, and Permanent Virtual Connections (PVC), which have associated Committed Information Rates (CIRs).

The Frame Relay Access Connection element provides access to GTA wire center equipped with a frame relay switch. A generic view of FRAS access is shown in Section 9, Original Page 67 & 68 following.

The Frame Relay Access Connection combines a frame relay compatible 56.0 kbps, 64.0 kbps, 1.544 Mbps or 44.736 Mbps digital transport facility with a port on a frame relay switch. The Frame Relay Access Connection includes GTA facility between the customer designated premises and the customer's serving wire center, the interoffice transport (if applicable) between the customer's serving wire center and wire center equipped with a frame relay switch, and the end user port. The end user port is a user-to-network interface, which provides the line side physical entry point into GTA frame relay network and permits FRAS compatible end user customer premises equipment (CPE) to originate or terminate an intrastate access service. Connections between end user customer premises equipment and GTA frame relay switch are available at speeds of 56.0 kbps, 64.0 kbps, 1.544 Mbps or 44.736 Mbps. Each end user port requires the identification of a corresponding terminating port. All end user ports must be in conformance with American National Standards Institute (ANSI) standards T1.606-addendum 1-1991, T1.606a-1992, T1.617, Annex D-1992.

GTA will provide the logical circuits required within its frame relay network to connect the ports or to connect a port with a DSL Access Service Connection Point. These logical circuits, or Permanent Virtual Connections (PVC), are software defined, end-to-end, bi-directional communications paths that are established and dis-established via the access service order process. While no physical circuits are dedicated, the two network addresses (one from each port) are connected electronically to form a PVC.

The standard PVC establishes a communications path between two ports or between a port and a DSL Access Service Connection Point within GTA frame relay network. A generic view of interconnected FRAS is show in Section 9, Original Page 67 & 68 following.

By: Tariff Administrator
Title:
Issued:

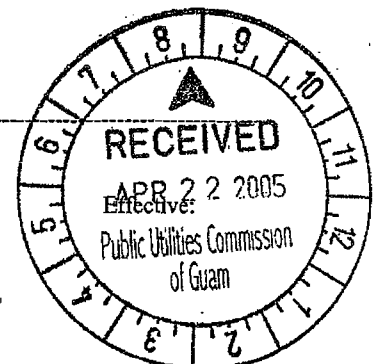

SPECIAL ACCESS SERVICE

XI. PUBLIC PACKET DATA NETWORK (cont'd)

FRAME RELAY ACCESS SERVICE (cont'd)

C. ORDERING OPTIONS AND CONDITIONS

At the time service is ordered, the number of PVCs will be identified along with their Committed Information Rates. CIR is the bit rate at which the FRAS network commits to transfer data. Committed Information Rates provide for frame relay switch throughput at designated speeds (See Section 9, Original Page 67 & 68 following). This information is required for network routing purposes.

Frame Relay Access Service is ordered under Special Access provisions set forth in Section 9. Also included in that section are other charges, which may be associated with ordering FRAS (e.g., Service Date Change Charges, Cancellation Charges, etc.). A minimum of two FRAS connections are required for data to be transported between customers designated premise

D. ACCEPTANCE TESTING

At no additional charge GTA will, at the customer's request, cooperatively test at the time of installation.

E. RATE REGULATIONS

This section contains the specific regulations governing the rates and charges that apply for Frame Relay Access Service.

1. Rate Categories

The following diagram depicts a generic view of the components of Frame Relay Access Service. (C)

By: Tariff Administrator
Title:
Issued:



Effective:

SPECIAL ACCESS SERVICE

XI. PUBLIC PACKET DATA NETWORK (cont'd)

FRAME RELAY ACCESS SERVICE (cont'd)

E. Rate Regulations (cont'd)

1. Rate Categories (cont'd)

Frame Relay Access Service

(D)

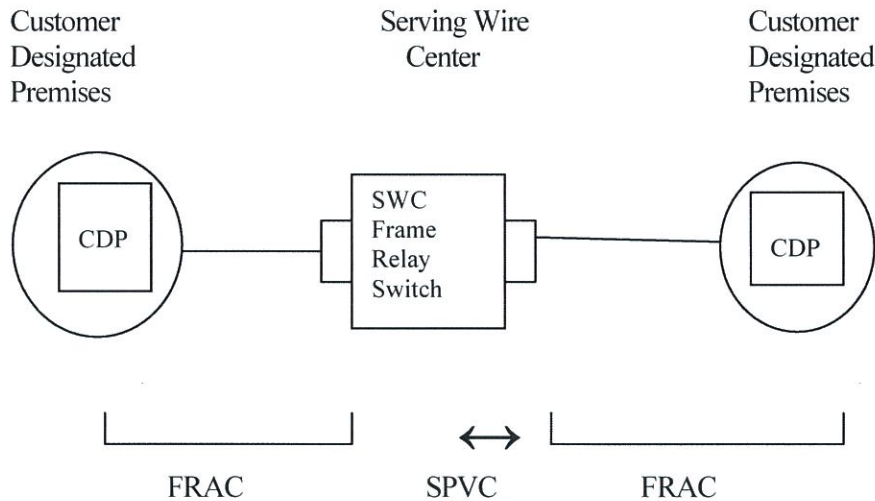

Rate Elements

FRAC = Frame Relay Access Connection
SPVC = Standard Permanent Virtual Connection

By: Tariff Administrator
Title:
Issued:



Effective:

SPECIAL ACCESS SERVICE

XI. PUBLIC PACKET DATA NETWORK (cont'd)

FRAME RELAY ACCESS SERVICE (cont'd)

E. Rate Regulations (cont'd)

1. Rate Categories (cont'd)

(D)

(D)

By: Tariff Administrator
Title:
Issued:



Effective:

SPECIAL ACCESS SERVICE

XI. PUBLIC PACKET DATA NETWORK (cont'd)

FRAME RELAY ACCESS SERVICE (cont'd)

E. RATE REGULATIONS (cont'd)

1. Rate Categories (cont'd)

(1) Frame Relay Access Connection

The Frame Relay Access connection (FRAC) rate element recovers the costs associated with the communication path between the end user's premises and GTA wire center equipped with a frame relay switch. The FRAC includes the physical transmission facility between the customer designated premises and the customer's serving wire center and the end user port on GTA frame relay switch. (C)

One FRAC charge applies per customer-designated premises at which the FRAS connection is terminated. This applies even if the customer designated premises and the frame relay switch are collocated in GTA's building.

(2) End User Port

An End User Port charge is applied as a discrete rate element in conjunction with Special Access Service. Refer to Section 9, Page 37 proceeding for additional applicable rates and charges.

The End User Port is the physical location in GTA switching office where the transport facility of the customer connects to the ERAS Network. It specifies how a frame relay switch sends and receives data from a frame relay end user customer's LAN or other compatible CPE devices.

By: Tariff Administrator
Title:
Issued:



Effective:

SPECIAL ACCESS SERVICE

XI. PUBLIC PACKET DATA NETWORK (cont'd)

FRAME RELAY ACCESS SERVICE (cont'd)

E. Rate Regulations (cont'd)

1. Rate Categories (cont'd)

(3) Permanent Virtual Connection (PVC)

A PVC is a software defined communications path between two port connections.

Each PVC is provisioned with a customer selected Committed Information Rate. The CIR is a transmission speed specified by the customer. CIRs range from 8 kbps to 768 kbps. GTA will provide switch capacity to permit the customer to transmit information with guaranteed delivery at the specified CIR. GTA will permit customers to attempt to transmit at speeds up to two times the CIR with no guarantee of completion. Attempted transmissions at above two times the CIR will not be permitted.

Customers will be permitted to order multiple PVCs on a given port subject to switch limitations. Customers anticipating non-simultaneous transmission may order CIRs assigned to these multiple PVCs, the sum of which may theoretically exceed the actual throughput of the port. However, when simultaneous transmission of multiple PVCs occurs, the total of the transmission rate (CIRs) may not exceed the actual throughput of the port.

The standard PVC establishes a communications path between two ports within the frame relay network.

2. Types of Rates and Charges

There are two types of rates and charges. They are monthly rates and nonrecurring charges. The rates and charges are described as follows:

By: Tariff Administrator
Title:
Issued:

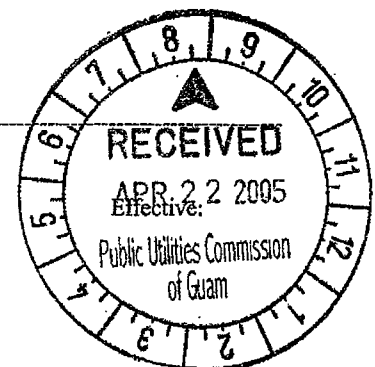

SPECIAL ACCESS SERVICE

XI. PUBLIC PACKET DATA NETWORK (cont'd)

FRAME RELAY ACCESS SERVICE (cont'd)

E. Rate Regulations (cont'd)

2. Types of Rates and Charges (cont'd)

a. Monthly Rates

Monthly rates are recurring rates that apply that apply each month or fraction thereof that an ERAS is provided. For billing purposes, each month is considered to have 30 days.

b. Nonrecurring Charges

Nonrecurring charges are one-time charges that apply for specific work activity (i.e., installation or change to an existing service). The types of nonrecurring charges that apply for FRAS are: installation of service and service rearrangements. Service Order Charges are in addition as specified in Section 3 Original Page 5 following:

(1) Installation of Service

Nonrecurring charges apply for the installation of Frame Relay Access Connections (FRAC), and Permanent Virtual Connections (PVC).

A nonrecurring charge applies per FRAC or FRIC installed and is based on the speed of the connection.

A nonrecurring charge applies per PVC installed.

Service Rearrangements

Services Rearrangements are changes to existing (installed) services.

By: Tariff Administrator
Title:
Issued:

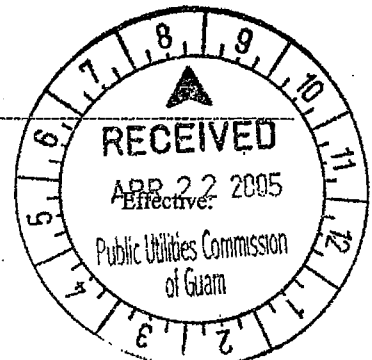

SPECIAL ACCESS SERVICE

XI. PUBLIC PACKET DATA NETWORK (cont'd)

FRAME RELAY ACCESS SERVICE (cont'd)

E. Rate Regulations (cont'd)

2. Types of Rates and Charges (cont'd)

b. Nonrecurring Charges (cont'd)

(2) Service Rearrangements (cont'd)

A PVC Rearrangements Charge will be applied whenever a change is made to the CIR of an existing PVC after initial port installation and/or a change is made to the terminating port destination of the PVC.

Administrative changes will be made without charge(s) to the customer. Administrative changes are as follows:

Change of customer name,

Change of customer or customer's end user premises
address when the change of address is not a result of
physical relocation of equipment

Change in billing data (name, address, or contact
name or telephone number),

Change of agency authorization,

Change of customer circuit identification,

Change of billing account number,

Change of customer or customer's end user contact
name or telephone number, and Change of jurisdiction.

By: Tariff Administrator
Title:
Issued:

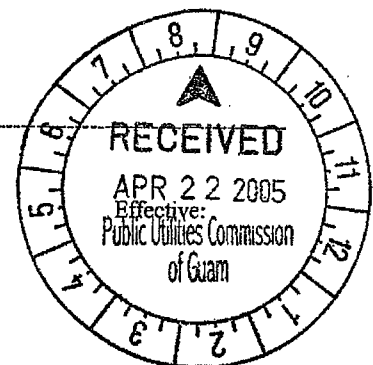

SPECIAL ACCESS SERVICE

XI. PUBLIC PACKET DATA NETWORK (cont'd)

FRAME RELAY ACCESS SERVICE (cont'd)

E. RATE REGULATIONS (cont'd)

2. Types of Rates and Charges (cont'd)

(b). Nonrecurring Charges (cont'd)

(3) Moves

A move involves a change in the physical location of one of the following:

- The Point of Termination at the Customer's premises
- The customer's premises.

The charges for the move are dependent on whether the move is to a new location within the same building or to a different building.

(i) Moves Within the Same Building

When the move is to a new location within the same building, the charge for the move will be an amount equal to one half of the nonrecurring (i.e., installation) charge for the service termination affected. There will be no change in the minimum period requirements. This charge is in addition to the Service Order Charge as specified in Section 3, Original Page 5 following.

By: Tariff Administrator
Title:
Issued:

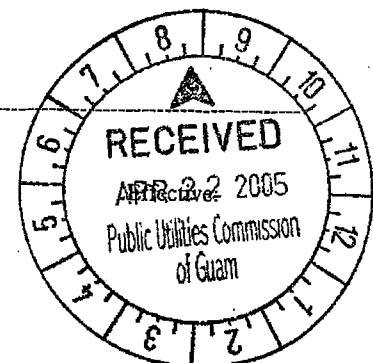

SPECIAL ACCESS SERVICE

XI. PUBLIC PACKET DATA NETWORK (cont'd)

FRAME RELAY ACCESS SERVICE (cont'd)

E. Rate Regulations (cont'd)

2. Types of Rates and Charges (cont'd)

b. Nonrecurring Charges (cont'd)

(i) Moves to a Different Building

Moves to a different building will be treated as a discontinuance and start of service and all associated nonrecurring charges will apply. New minimum period requirements will be established for the new services. The customer will also remain responsible for satisfying all outstanding minimum period charges for the discontinued service.

c. Rates and Charges

	<u>Monthly Rate</u>	<u>Nonrecurring Rate</u>
Frame Relay Connection		
-56 kbps	\$ 135.00	\$177.00
- 65 kbps \$135.00	\$177.00	
- 1.544 kbps	\$340.00	\$181.00
- 44.736 kbps	\$2,710.00	\$499.00
Frame Relay Inter-network		
- 1.544 mbps	\$340.00	\$181.00
- 44.736 mbps	\$2,710.00	\$49.00
End User Port		
- 56 kbps	\$70.00	
- 65 kbps	\$70.00	
- 1.544 mbps	\$163.00	
- 44.736 mbps	\$1,140.00	

By: Tariff Administrator
Title:
Issued:



SPECIAL ACCESS SERVICE

XI. PUBLIC PACKET DATA NETWORK (cont'd)

FRAME RELAY ACCESS SERVICE (cont'd)

E. RATE REGULATIONS (cont'd)

2. Types of Rates and Charges (cont'd)

c. Rates and Charges (cont'd)

	<u>Monthly Rate</u>	<u>Nonrecurring Rate</u>
Inter-Network Customer Port		
-- 1.544 mbps	\$163.00	
-- 44.736 mbps	\$1,140.00	
Standard Permanent Virtual Connection		
-- 8kbps	\$5.00	
-- 15 kbps	\$5.00	
-- 28 kbps	\$6.00	
-- 32 kbps	\$6.00	
-- 56 kbps	\$7.00	
-- 64 kbps	\$7.00	
-- 128 kbps	\$9.00	
-- 192 kbps	\$12.00	
-- 256 kbps	\$14.00	
-- 384 kbps	\$20.00	
-- 512 kbps	\$28.00	
-- 768 kbps	\$36.00	

By: Tariff Administrator
Title:
Issued:

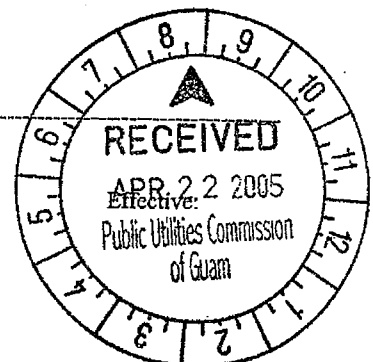

SPECIAL ACCESS SERVICE

XI. PUBLIC PACKET DATA NETWORK (cont'd)

FRAME RELAY ACCESS SERVICE (cont'd)

E. Rate Regulations (cont'd)

2. Types of Rates and Charges (cont'd)

c. Rates and Charges (cont'd)

	<u>Monthly Rate</u>	<u>Nonrecurring Rate</u>
Extended Permanent Virtual Connection		
- 8 kbps	\$6.00	
- 18 kbps	\$6.00	
- 28 kbps	\$7.00	
- 32 kbps	\$7.00	
- 56 kbps	\$8.00	
- 64 kbps	\$8.00	
- 128 kbps	\$15.00	
- 192 kbps	\$25.00	
- 256 kbps	\$30.00	
- 384 kbps	\$45.00	
- 512 kbps	\$60.00	
- 768 kbps	\$90.00	
PVC Installation Charge, Per Occurrence		\$50.00
PVC Rearrangement Charge, Per Occurrence		\$25.00

C. Minimum Period

The minimum period for FRAS is one month and the full monthly rate will apply to the first month. Adjustments for quantities of services established or discontinued in any billing period beyond the minimum period are as set forth in Section 3, Original Page 5.

By: Tariff Administrator
Title:
Issued:
9214763v1

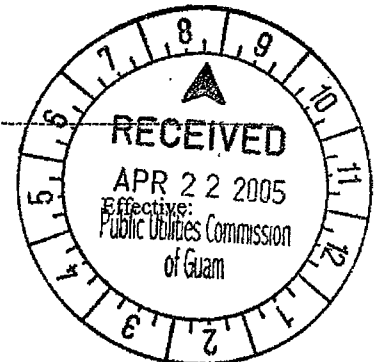

XII. METRO ETHERNET TRANSPORT SERVICES (ETS)

A. GENERAL

Ethernet Transport Service (ETS) is a high speed data transport service that provides end-to-end transmission using Ethernet packet technology at transport speeds ranging from 5 Mbps to 1 Gbps, where available. ETS is ideal for transport of broadband multimedia traffic (i.e., voice, data and video) using variable length Ethernet packets with the ability to interconnect multiple locations using GTA's network. Ethernet packets generated by Ethernet-compatible customer premises equipment (CPE) are transmitted using available capacity on shared transmission paths through GTA's network to a pre-specified destination. The ETS customer may use ETS to: (1) interconnect customer designated premises (CDPs) served by GTA's ETS Point-to-Point network and/or (2) interconnect with its local area network (LAN) to GTA's ETS Point-to-Point network.

B. SERVICE DESCRIPTION

1. ETS is provided using a combination of ETS Channel Terminations (ETS CTs), ETS Ports, ETS Ethernet Virtual Connections (ETS EVCs), and ETS Extended Ethernet Virtual Connection (ETC E-EVCs). ETS may be used in conjunction with Special Access High Capacity DS3 and Synchronous Optical Services OC-3 and OC-12 Services as specified in this Section 7 preceding.
2. An ETS Port is required to provide the interface GTA's ETS Point-to-Point network. ETS EVCs establish a shared transmission path between any two ETS Ports on GTA's ETS Point-to-Point network.
3. The transmission quality of ETS is not guaranteed and is offered to ETS Customers at the best effort level. GTA's ETS Point-to-Point network will attempt to deliver all Ethernet packets received; however, network congestion may result in a loss of Ethernet packets. Transmission speeds may be affected by facilities and by distance from GTA's Central Office (CO) and other technical limitations in the GTA network and are not guaranteed.

By: Eric Votaw
Title: Vice President - Regulatory
Issued: September 29, 2007

Effective: October 28, 2007



SPECIAL ACCESS SERVICE

XII. METRO ETHERNET TRANSPORT SERVICES (ETS)

B. SERVICE DESCRIPTION (cont'd)

4. Rates and charges for ETS are specified in Section 7, following. The application of rates and charges for ETS is described later in this Section.

C. OBLIGATIONS OF THE CUSTOMER

In addition to the regulations described in other Section of this Tariff, the following provisions apply to ETS:

1. When placing an order, the customer must specify:
 - i. Customer designated premises
 - ii. Type(s) of ETS Port Interface(s)
 - iii. Speed for each ETS Port
 - iv. Number and bandwidth capacity required from the GTA Ethernet Point-to-Point network.
 - v. Options desired.
2. When connecting to the ETS Port of another Customer, the ordering Customer must obtain authorization from the other Customer and provide such authorization to GTA.
3. The ETS Customer is responsible for providing and maintaining all required Customer Premises Equipment (CPE), which is compatible with ETS and complies with the standards specified in the Technical Reference IEEE Standard 802.3, Part 3.

D. RATE CATEGORIES

This section contains the regulations governing the rates and charges that apply for ETS. Regulations governing the rates and charges for Special Access provided under this tariff are used in conjunction with ETS are specified in this Tariff proceeding.

The following diagram depicts a generic view of the elements of ETS as provided by GTA. The ETS customer's CDPs are served by a single ETS SWC. ETS EVCs are ordered between two ETS Intraswitch EVCs. The ETS customer orders the applicable ETS elements from GTA pursuant to the provisions specified in this section. (C)
(C)
(C)

By: Tariff Administrator
Title:
Issued:



Effective:

SPECIAL ACCESS SERVICE

XII. METRO ETHERNET TRANSPORT SERVICES (ETS)

D. RATE CATEGORIES (cont'd)

Figure 1

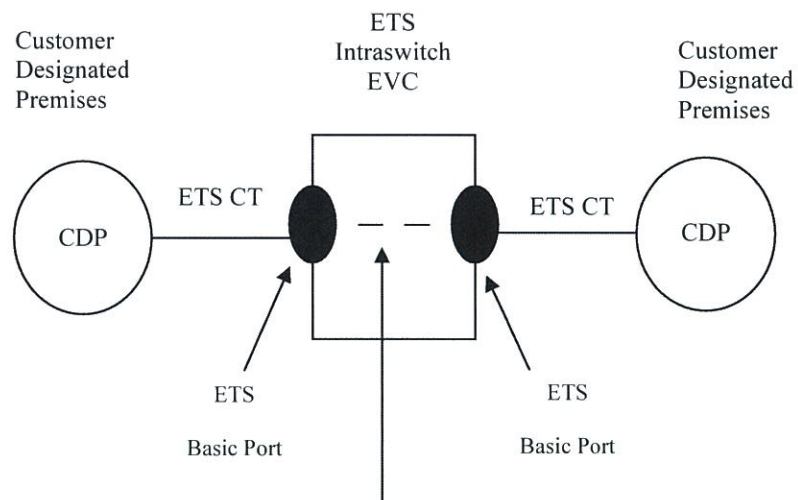

(D)

(D)

By: Tariff Administrator
Title:
Issued:



Effective:

SPECIAL ACCESS SERVICE

XII. METRO ETHERNET TRANSPORT SERVICES (ETS)

D. RATE CATEGORIES (cont'd)

(D)
|
(D)

(1) ETS Channel Terminations (CTs)

An ETS CT provides the transport facility between the customer's designated premises and an ETS Basic Port at the Telephone Company's ETS SWC. (C)

ETS CTs are available at bandwidth speeds of 2 Mbps, 5 Mbps, 10 Mbps, 20 Mbps, 50 Mbps, 100 Mbps, 250 Mbps, 500 Mbps, 750 Mbps, and 1 Gbps. The ETS customer orders the type of ETS CT it needs based on its bandwidth requirements. Bandwidth speeds of 50 Mbps and above require use of a fiber loop facility, where such fiber facilities exist. ETS CTs are available only from a suitably equipped ETS SWC for connection to ETS Basic Ports. (C) (T)

A Special Access High Capacity DS3 or Synchronous Optical Channel Service OC3 or OC12 Channel Termination may also be used to connect a CDP to the Telephone Company's ETS SWC for connection to an ETS Interconnection Port. The provisions for Special Access Channel Terminations are specified in Section 7, preceding. (C)

By: Tariff Administrator
Title:
Issued:



Effective:

XII METRO ETHERNET TRANSPORT SERVICES (ETS) (cont'd)

D. RATE CATEGORIES (cont'd)

1. ETS Channel Terminations (CTs) (cont'd)

Monthly and nonrecurring charges apply for each ETS CT ordered. The monthly rate is based upon the bandwidth capacity ordered and whether the CDP is located within 300 feet of the ETS SWC or more than 300 feet from the ETS SWC. Rates and charges are specified in Section 8.E following

2. ETS Ports

ETS Ports provide the interface at GTA's ETS SWC for data traffic to and from the customer premises equipment as well as for connecting the GTA's ETS Point-to-Point network to an Ethernet network outside of GTA's ETS Point-to-point network. An ETS Port receives Ethernet packets from the ETS customer's Ethernet-compatible CPE, validates the addressing parameters contained in the packet headers, and transmits the packets into the ETS network. The ETS Port also receives Ethernet packets from the GTA's ETS Point-to-Point network or from an Ethernet network located outside of the GTA's ETS Point-to-Point network, validates the addressing parameters contained in the packet headers, and transmits the packets to the pre-designated CDP.

There are two types of ETS ports available, i.e., ETS Basic Port and ETS Interconnection Ports.

- i. **ETS Basic Ports** provide the interface to GTA's ETS Point-to-Point network and do not include the required transport facility between the CDP and GTA's ETS SWC. ETS Basic Ports are available with bandwidth speeds of 10 Mbps to 1 Gbps. Required transport to the ETS Basic Port is provided using an ETS CT as described above. Each ETS Basic Port must be associated with a minimum of one ETS EVC, or one ETS E-EVC. An ETS Basic Port may be associated with more than one ETS EVC or ETS E-EVC. The bandwidth speed of an ETS Basic Port must be equal to or greater than the bandwidth speed of the associated ETS CT.
- ii. **ETS Interconnection Ports** also provide the interface to GTA's ETS Point-to-Point network and do not include the required transport facility between the CDP and the GTA's ETS SWC. Used in conjunction with Special Access DS3, OC3 and/or OC12 Services, ETS Interconnection Ports permit the ETS customer to:



By: Eric Votaw
Title: Vice President - Regulatory
Issued: September 29, 2007

Effective: October 28, 2007

XII. METRO ETHERNET TRANSPORT SERVICES (ETS) (cont'd)

D. RATE CATEGORIES (cont'd)

2. ETS Ports (cont'd)

1.) connect a CDP served by an ETS or non-ETS SWC to the GTA's ETS network. ETS Interconnection Ports are available at bandwidth speeds of 44.736 Mbps (DS3), 155.52 Mbps (OC3) and 622.08 Mbps (OC12).

Required transport to the ETS Interconnection Port is provided using Special Access DS3, OC3 and/or OC12 Service facilities as described in this Section 7, preceding. Each ETS Interconnection Port must be associated with a minimum of one ETS EVC or one ETS E-EVC. An ETS Interconnection Port may be associated with more than one ETS EVC or ETS E-EVC. The bandwidth speed of an ETS Interconnection Port must be equal to the bandwidth speed of the associated Special Access Service Channel Termination.

Monthly and nonrecurring charges apply for each ETS Port ordered. The monthly recurring charge is determined by the capacity and type of ETS Port ordered. Rates and charges are specified in Section(s) 7.D and 7.E, following.

3. ETS Ethernet Virtual Connections (ETS EVCs)

ETS EVCs are logical associations established by GTA across a shared transmission path that allow the ETS customer to transmit packets between any two ETS Ports located on GTA's ETS Point-to-Point network. ETS EVCs are available in fixed bandwidth amounts of 5 Mbps to 1 Gbps. GTA will establish ETS EVCs used upon the bandwidth capacity specified by the ETS customer on its Access Order. When ETS EVCs are ordered between two ETS Ports in the same SWC, the ETS customer will be charged the ETS Intraswitch EVC rate. When ETS EVCs are ordered between ETS Ports that are in different SWCs within GTA's serving territory, the ETS customer will be billed the ETS Interswitch EVC rate.

By: Eric Votaw
Title: Vice President - Regulatory
Issued: September 29, 2007

Effective: October 28, 2007

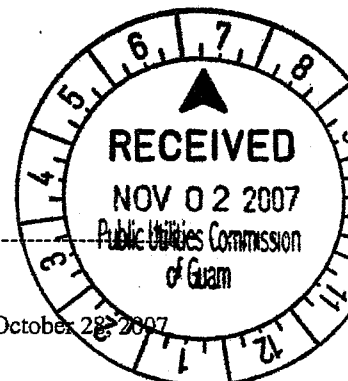

XII. METRO ETHERNET TRANSPORT SERVICES (ETS) (cont'd)

D. RATE CATEGORIES (cont'd)

3. ETS Ethernet Virtual Connections (ETS EVCs) (cont'd)

Monthly and nonrecurring charges apply for each ETS EVC ordered. The monthly recurring charge is based upon the bandwidth capacity ordered and whether the associated ETS Ports are located within one SWC (Intraswitch) or between different SWCs (Interswitch). Rates and charges are specified in Section 8.E following.

4. RESERVED FOR FUTURE USE

5. Types of Rates and Charges

There are two types of rates and charges. They are monthly rates and nonrecurring charges. The rates and charges are described below:

i. Monthly Rates

Monthly rates are recurring rates that apply each month or fraction thereof when an ETS service element is provided. For billing purposes, each month is considered to have 30 days.

By: Eric Votaw
Title: Vice President - Regulatory
Issued: September 29, 2007

Effective: October 28, 2007

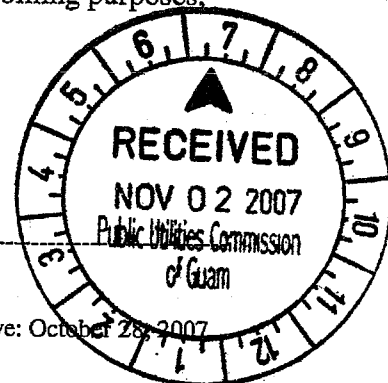

XII. METRO ETHERNET TRANSPORT SERVICES (ETS) (cont'd)

D. RATE CATEGORIES (cont'd)

5 Types of Rates and Charges (cont'd)

ii. Nonrecurring Charges

Nonrecurring charges are one-time charges that apply for specific work activity (i.e., installation or change to an existing service). The types of nonrecurring charges that apply for ETS are installation of service, service rearrangements, moves and design changes.

Except as specified below, these charges are in addition to the Access Order Charge as specified in Section 8.E, following.

(a) Installation of Service

Nonrecurring charges apply for installation of ETS CTs, ETS Ports, ETS EVCs, and ETS Optional Features and functions ordered by the ETS customer.

(b) Service Rearrangements

Service rearrangements are changes to existing (i.e., installed) services, which may be administrative only in nature as set forth below or, that involve an actual physical change to the service.

When the ETS customer elects to decrease the bandwidth capacity on existing ETS Ports, and associated ETS CTs, the request will be considered a discontinuance of service for the former capacity and start of service for the new capacity. Associated nonrecurring (i.e., installation) charges will apply. New minimum period requirements will be established for the new ETS elements. The ETS customer will also remain responsible for satisfying all outstanding minimum period charges for the discontinued ETS elements.

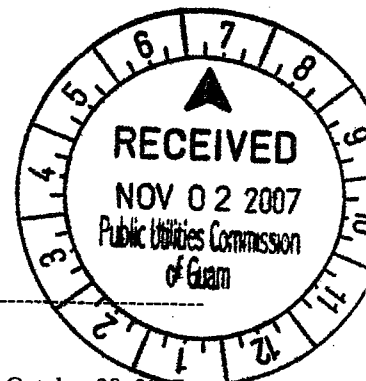

XII. METRO ETHERNET TRANSPORT SERVICES (ETS) (cont'd)

D. RATE CATEGORIES (cont'd)

5 Types of Rates and Charges (cont'd)

ii. Nonrecurring Charges (cont'd)

(b) Service Rearrangements (cont'd)

When the ETS customer elects to increase the bandwidth capacity on existing ETS Ports and associated ETS CTs, the request will be considered a discontinuance of service for the former capacity and start of service for the new capacity. Associated nonrecurring (i.e., installation) charges will apply. New minimum period requirements will be established for the new ETS elements. Any outstanding minimum period charges associated with the discontinued ETS elements that would otherwise be applicable for the bandwidth capacity upgrades described in this paragraph will be waived.

When the ETS customer elects to change the bandwidth capacity on existing ETS EVCs, (i.e., the customer requests an increase or decrease in capacity), the ETS Design Change Charge described in (d), below, will apply per ETS element changed.

When the ETS customer elects to remove existing ETS EVCs or ETS E-EVCs, the ETS Design Change Charge described in (d), below, will apply per ETS EVC removed.

Administrative changes are as follows:

- Change of customer name,
- Change of customer or customer's end user premises address when the change of address is not a result of physical relocation of equipment,
- Change in billing data (name, address, or contact name or telephone number),
- Change of agency authorization,
- Change of customer circuit identification,
- Change of billing account number,
- Change of customer or customer's end user contact name or telephone number.



By: Eric Votaw
Title: Vice President - Regulatory
Issued: September 29, 2007

Effective: October 28, 2007

XII. METRO ETHERNET TRANSPORT SERVICES (ETS) (cont'd)

D. RATE CATEGORIES (cont'd)

6 Types of Rates and Charges (cont'd)

ii. Nonrecurring Charges (cont'd)

(b) Service Rearrangements (cont'd)

(c) Moves

A move involves a change in the physical location of one of the following:

- The Point of Termination at the customer's premises
- The customer's premises

The charges for moving ETS elements are dependent on whether the move is to a different location within the same building, to a different building within the same SWC, or to a different building in a different SWC. The charges specified below apply in addition to any applicable charges for moving any applicable Special Access Services as specified in this Tariff preceding.

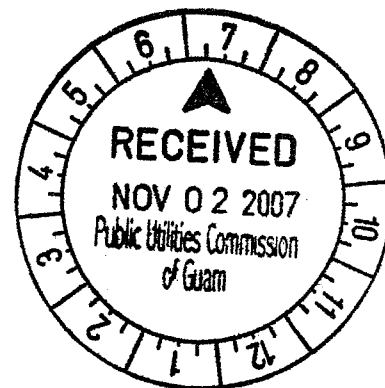

By: Eric Votaw
Title: Vice President - Regulatory
Issued: September 29, 2007

Effective: October 28, 2007

XII. METRO ETHERNET TRANSPORT SERVICES (ETS) (cont'd)

D. RATE CATEGORIES (cont'd)

5. Types of Rates and Charges (cont'd)

(c) Moves (cont'd)

(i) Moves Within the Same Building

ETS Basic and Interconnection Ports, and ETS EVCs are not impacted when an ETS customer moves its Point of Termination to a different location within the same building. The charge for moving an ETS CT within the same building will be an amount equal to one half of the nonrecurring (i.e., installation) charge for the ETS CT. There will be no change in the minimum period requirements.

(ii) Moves To a Different Building Within the Same SWC

ETS Basic and Interconnection Ports, and ETS EVCs are not impacted when an ETS customer moves its Point of Termination to a different building within the same SWC. The move of an ETS CT will be treated as a discontinuance and start of service. Associated nonrecurring (i.e., installation) charges will apply. New minimum period requirements will be established for the new services. The ETS customer will also remain responsible for satisfying all outstanding minimum period charges for the discontinued service.

(iii) Moves to a Different Building in a Different SWC

A move to a different building in a different SWC will be treated as a discontinuance and start of service of all associated ETS elements. Associated nonrecurring (i.e., installation) charges will apply. New minimum period requirements will be established for the new services. The ETS customer will also remain responsible for satisfying all outstanding minimum period charges for the discontinued service.



XII. METRO ETHERNET TRANSPORT SERVICES (ETS) (cont'd)

D. RATE CATEGORIES (cont'd)

5. Types of Rates and Charges (cont'd)

d) ETS Design Changes

As described in (b), above, the ETS Design Change Charge specified in Section 8.E following, will apply when the ETS customer elects to: (1) change the bandwidth capacity of existing ETS EVCs, or (2) remove existing ETS EVCs.

When applicable, the ETS Design Change Charge applies in lieu of the ETS EVC nonrecurring charge. The Access Order Charge will not apply when the ETS Design Change Charge is applicable.



By: Eric Votaw
Title: Vice President - Regulatory
Issued: September 29, 2007

Effective: October 28, 2007

SPECIAL ACCESS SERVICE

XII. METRO ETHERNET TRANSPORT SERVICES (ETS)

E. RATES AND CHARGES

1. ETS Channel Terminations

- (a) Per termination when customer designated premises located within 300 feet of ETS SWC

<u>Capacity</u>	<u>Monthly Rate</u>	<u>Nonrecurring Charge</u>
2 Mbps	\$ 62.54	\$295.00
5 Mbps	\$ 63.23	\$295.00
10 Mbps	\$ 64.13	\$295.00
20 Mbps	\$ 70.41	\$295.00
50 Mbps	\$ 81.40	\$295.00
100 Mbps	\$ 90.45	\$295.00
250 Mbps	\$ 94.47	\$295.00
500 Mbps	\$ 168.83	\$442.00
750 Mbps	\$ 196.70	\$442.00
1 Gbps	\$ 224.58	\$442.00

(C)

 (C)

- (b) Per termination when customer designated premises located more than 300 feet of ETS SWC

<u>Capacity</u>	<u>Monthly Rate</u>	<u>Nonrecurring Charge</u>
2 Mbps	\$171.02	\$295.00
5 Mbps	\$172.92	\$295.00
10 Mbps	\$175.37	\$295.00
20 Mbps	\$198.38	\$295.00
50 Mbps	\$224.26	\$295.00
100 Mbps	\$234.66	\$295.00
250 Mbps	\$245.08	\$295.00
500 Mbps	\$324.22	\$442.00
750 Mbps	\$378.25	\$442.00
1 Gbps	\$432.29	\$442.00

(C)

 (C)

(D)

 (D)

By: Tariff Administrator
 Title:
 Issued:



Effective:

SPECIAL ACCESS SERVICE

XII. METRO ETHERNET TRANSPORT SERVICES (ETS)

E. RATES AND CHARGES

2. Ports

(a) Per ETS Basic Port

<u>Capacity</u>	<u>Monthly Rate</u>	<u>Nonrecurring Charge</u>	
2 Mbps	\$61.93	\$259.00	(C)
5 Mbps	\$68.56	\$259.00	
10 Mbps	\$75.71	\$259.00	
20 Mbps	\$84.12	\$259.00	
50 Mbps	\$89.15	\$259.00	
100 Mbps	\$97.27	\$259.00	
250 Mbps	\$134.26	\$259.00	
500 Mbps	\$170.21	\$388.00	
750 Mbps	\$214.79	\$388.00	
1 Gbps	\$259.38	\$388.00	

(b) Per ETS Interconnection Port

<u>Capacity</u>	<u>Monthly Rate</u>	<u>Nonrecurring Charge</u>	
44.736 Mbps	\$1,009.47	\$175.00	(C)
155.52 Mbps	\$1,211.37	\$262.00	(C)
622.08 Mbps	\$2,018.95	\$262.00	(C)

(D)
 (D)

By: Tariff Administrator
 Title:
 Issued:



Effective:

SPECIAL ACCESS SERVICE

XII. METRO ETHERNET TRANSPORT SERVICES (ETS)

E. RATES AND CHARGES

3. ETS Ethernet Virtual Connections (EVCs)

(a) Per Intraswitch ETS EVC

<u>Capacity</u>	<u>Monthly Rate</u>	<u>Nonrecurring Charge</u>
2 Mbps	\$0.00	\$205.00
5 Mbps	\$0.00	\$205.00
10 Mbps	\$0.00	\$205.00
20 Mbps	\$0.00	\$205.00
50 Mbps	\$0.00	\$205.00
100 Mbps	\$0.00	\$205.00
250 Mbps	\$0.00	\$205.00
500 Mbps	\$0.00	\$307.00
750 Mbps	\$0.00	\$307.00
1 Gbps	\$0.00	\$307.00

(C)
|
(C)

(D)
|
(D)

By: Tariff Administrator
Title:
Issued:



Effective: